



VARIABLE REFRIGERANT FLOW SYSTEMS



 United Technologies

turn to the experts 

Index

VRF System - Outdoor Units	11
Indoor Units: Cassettes	55
Indoor Units: Duct	63
Indoor Units: Wall, Ceiling, Floor	71
Control Systems	85
Heat Recovery Ventilator	101
Branch Pipe	107



WEATHERMAKERS
TO THE **WORLD**

Built on Willis Carrier's invention of modern air-conditioning in 1902, Carrier is the world leader in heating, air-conditioning and refrigeration solutions. Carrier constantly builds upon its history of proven innovation with new products and services that improve global comfort and efficiency.



The Invention That Changed the World

In 1902, Willis Carrier solved one of mankind's most elusive challenges by controlling the indoor environment through modern air-conditioning. His invention enabled countless industries, promoting global productivity, health and personal comfort.

Today, Carrier innovations are found across the globe and in virtually every facet of daily life. Carrier creates comfortable and productive environments, regardless of the climate, safeguards the global food supply by preserving the quality and freshness of food and beverages, ensures health and well-being by enabling the proper transport and delivery of vital medical supplies under exacting conditions and provides solutions, services and education to lead the green building movement. These mark just a handful of the ways that Carrier works to make the world a better place to live, work and play.

AHI CARRIER SOUTH EASTERN EUROPE AIR CONDITIONING S.A.

Dating back to 1952, Carrier was the first air-conditioning company in Greece. In 1996, Carrier Hellas Air-Conditioning S.A. was established as a subsidiary of Carrier Corporation with distribution and after sales services rights for Carrier, Toshiba & Totaline air-conditioning brands in Greece.

Milestones

1999

Toshiba Carrier Corporation was established as a joint-venture between Toshiba Corporation air conditioner division and Carrier Corporation. With the advent of Toshiba Carrier Corporation, two great enterprises joined forces to deliver a wide range of air-conditioning solutions with the leading technology.

2004

Carrier expands its distribution rights to the Balkan area with subsidiary in Bulgaria.

2008

The expansion continues with a subsidiary office in Romania.

2009

The company is renamed to Carrier South Eastern Europe Air-Conditioning S.A. signifying the distribution rights in Greece, Cyprus and the Balkan region.

2011

Carrier enters into an agreement to transfer its HVAC distribution and after-sales support operations in Greece, Cyprus & the Balkans to its existing AHI Carrier FZC joint venture. The company is renamed to AHI Carrier South Eastern Europe Air -Conditioning S.A and continues to provide customers with high quality Carrier and Toshiba HVAC solutions, supported by dedicated after-sales service technicians and the Totaline parts and supply network.

2013

AHI Carrier SEE assumes the responsibility of the distribution rights for the Carrier RLC products in Central Europe.

2016

AHI Carrier SEE assumes also the responsibility of the distribution rights for Carrier products (RLC & BSS) in Central Europe and the offices in Austria & Czech are reporting to AHI SEE. AHI European total area management is unified under Greek office.



TOSHIBA & CARRIER



CARRIER

Company Culture

Mission

To be our customers' first choice for air-conditioning, heating and refrigeration solutions in our region.

Purpose

To create comfortable environment regardless of the climate by providing solutions that maintain exceptional indoor air quality.

Carrier delivers global solutions across a broad range of applications in heating, air conditioning, refrigeration and beyond

Home Comfort

Carrier heating and air-conditioning systems are trusted to bring energy-efficient, quiet, consistent comfort to millions of people at home.

Building Solutions

Carrier provides sustainable commercial heating and air-conditioning solutions for light commercial and commercial buildings.

Energy Management Solutions

Carrier Energy Management solutions provide end users with low energy, high performance and enhanced indoor air quality and comfort.

These energy management solutions are designed and developed with the support of engineers from Carrier Energy Management Centre of Excellence.

Their expertise ensure the solutions are fully tailored to meet the specific needs of each customer.

Transport Refrigeration

Carrier transport refrigeration equipment, cold chain monitoring solutions and replacement components ensure the safe, reliable transport of food and beverages, medical supplies and other perishable cargo to people and businesses around the world.

Commercial Refrigeration

Serving the beverage, food service and food retail industries, Carrier's refrigeration solutions are built on next generation technologies to preserve freshness, ensure safety and enhance appearances of global food and beverage retail.

Natural Leadership

From the very beginning, Carrier has been a natural leader. Not simply for the fact that Carrier creates an entirely new and innovative products, but because Carrier sets the standard in environmental responsibility. Since 1994, Carrier has led the industry in the phase-out of ozone-depleting refrigerants while introducing many of the world's most energy-efficient heating, air-conditioning and refrigeration systems.

Preservation of the environment and protecting our world's finite natural resources is a central tenet of Carrier's business as it recognizes the vital importance of maintaining a responsible balance between the comfort we create today and the world we live in tomorrow.







VRF System

Outdoor Units

Xpower Super Plus Series



- Heat pump
- High Efficiency
- Maximum 4 modules can be combined 8-88 HP
- High Reliability
- Anti-corrosion Protection
- All DC inverter compressors
- All DC fan motors
- Easy Installation and Service

Xpower Heat Recovery Series



- Heat recovery is achieved by diverting exhaust heat from indoor units in cooling mode to areas requiring heating
- Simultaneous cooling and heating operation in one system
- Maximum 4 modules can be combined 8~64HP
- All DC inverter compressors
- All DC fan motors
- Up to 64 indoor units can be operated in one system
- The MS equipment switches the system between cooling and heating modes

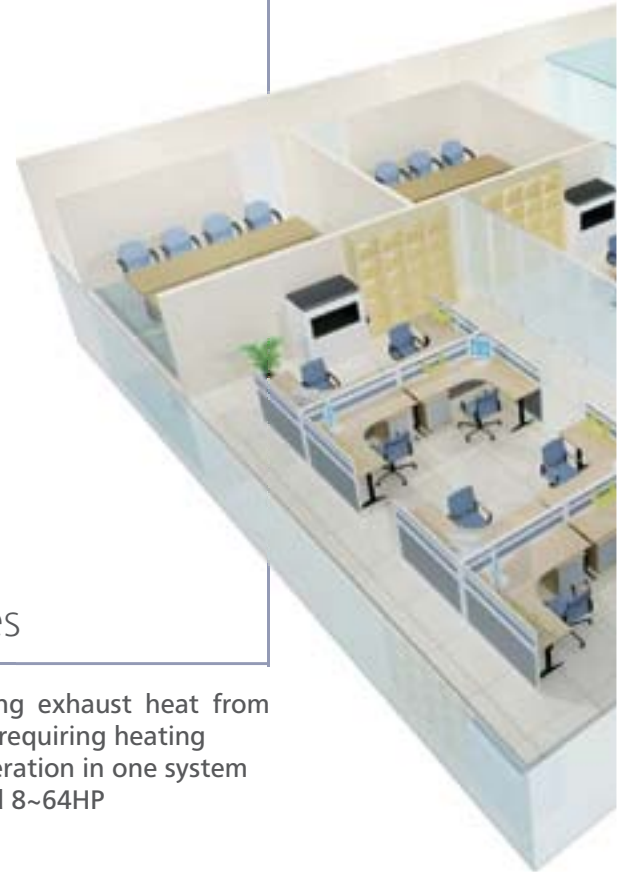

XPower Full DC Inverter Mini VRF Series (1-phase or 3-phase)



- Heat pump
- All DC inverter technology with all DC inverter compressors and all DC fan motors makes high energy efficiency
- Maximum 7 indoor units can be operated in one system
- Extensive capacity range from 4, 5, 6HP, making it particularly suitable for small offices, villas, shops, etc.

XPower Full DC Inverter Mini VRF / Side Discharge





- Heat pump
- All DC inverter technology
- Maximum 15 indoor units can be operated in one system
- Capacity range from 20kW to 45kW



Products Lineup



XPower Super Plus Series

Capacity	HP	8	10	12	14	16	18	20	22
	kW	25.2	28.0	33.5	40.0	45.0	50.0	56.0	61.5
									

XPower Heat Recovery R Series



Capacity	HP	8	10	12	14	16
	kW	25.2	28.0	33.5	40.0	45.0
						

XPower Mini VRF Series (1-phase or 3-phase)

Capacity	HP	4	5	6
	kW	12,3	14	15,5
				

XPower Mini VRF Series / Side Discharge

Capacity	HP	8	10	14	16
	kW	22.4	26.0	40.0	45.0
					

XPower Super Plus Series

XPower DC Inverter Super Plus Series is a range of high performance VRF outdoor units. With capacities ranging from 8HP to 88HP in 2HP increments, the Super Plus brings high efficiency, high reliability cooling and heating to projects large and small.

The Super Plus offers a variety of outstanding capabilities. Able to support piping lengths of up to 1000m and height differences of up to 110m, the Super Plus rises to the challenge of today's tall buildings. Compatibility with a wide selection of indoor units provides the flexibility to produce tailored climate control solutions for a wide range of interior spaces.



- DC inverter compressor
- DC fan motor
- Capacity up to 88HP
- Connectable indoor units quantity up to 64
- ESP up to 60Pa
- Cycle duty operation
- Backup operation
- Precise oil control technology
- Advanced silence technology
- Intelligent defrosting technology
- Simple communication wiring
- Auto addressing
- Easy maintenance



Indoor Units
Xpower VRF indoor unit



Fresh Air Processing Unit
100% fresh air supply



Ventilation
Heat recovery ventilator (HRV)



AHU Connection Kit
Connect to other brand AHU



Control Systems
Smart control systems



Recommended combination table



Outdoor Unit Combination

Model	N° of Outdoor units	N° of Compressors	8	10	12	14	16	18	20	22	Maximum N° of Connectable Indoor Units	Capacity	
												Cooling	Heating
38VF008H11901E	1	1	1								13	25.2	27.0
38VF010H11901E	1	1		1							16	28.0	31.5
38VF012H11901E	1	1			1						20	33.5	37.5
38VF014H11901E	1	2				1					23	40.0	40.0
38VF016H11901E	1	2					1				26	45.0	45.0
38VF018H11901E	1	2						1			29	50.0	50.0
38VF020H11901E	1	2							1		33	56.0	56.0
38VF022H11901E	1	2								1	36	61.5	61.5
38VF024H11901E	2	2			2						39	67.0	75.0
38VF026H11901E	2	3		1			1				43	73.0	76.5
38VF028H11901E	2	3		1				1			46	78.0	81.5
38VF030H11901E	2	3		1					1		50	84.0	87.5
38VF032H11901E	2	3		1						1	53	89.5	93.0
38VF034H11901E	2	3			1					1	56	95.0	99.0
38VF036H11901E	2	4						2			59	100.0	100.0
38VF038H11901E	2	4					1			1	63	106.5	106.5
38VF040H11901E	2	4						1		1	64	111.5	111.5
38VF042H11901E	2	4							1	1	64	117.5	117.5
38VF044H11901E	2	4								2	64	123.0	123.0
38VF046H11901E	3	4			2					1	64	128.5	136.5
38VF048H11901E	3	5		1			1			1	64	134.5	138.0
38VF050H11901E	3	5		1				1		1	64	139.5	143.0
38VF052H11901E	3	5		1					1	1	64	145.5	149.0
38VF054H11901E	3	5		1						2	64	151.0	154.5
38VF056H11901E	3	5			1					2	64	156.5	160.5
38VF058H11901E	3	6						2		1	64	161.5	161.5
38VF060H11901E	3	6					1			2	64	168.0	168.0
38VF062H11901E	3	6						1		2	64	173.0	173.0
38VF064H11901E	3	6							1	2	64	179.0	179.0
38VF066H11901E	3	6								3	64	184.5	184.5
38VF068H11901E	4	6			2					2	64	190.0	198.0
38VF070H11901E	4	7		1			1			2	64	196.0	199.5
38VF072H11901E	4	7		1				1		2	64	201.0	204.5
38VF074H11901E	4	7		1					1	2	64	207.0	210.5
38VF076H11901E	4	7		1						3	64	212.5	216.5
38VF078H11901E	4	7			1					3	64	218.0	222.0
38VF080H11901E	4	8						2		2	64	223.0	223.0
38VF082H11901E	4	8					1			3	64	229.5	229.5
38VF084H11901E	4	8						1		3	64	234.5	234.5
38VF086H11901E	4	8							1	3	64	240.5	240.5
38VF088H11901E	4	8								4	64	246.0	246.0

Notes:

1. The combinations of units shown in the table are factory-recommended. Other combinations of units are also possible.
2. For systems with two or more outdoor units, outdoor branch joints (sold separately) are required.

Large capacity for big sized buildings

The outdoor units capacity range from 8HP up to 88HP in 2HP increment, the Super Plus brings high efficiency, high reliability cooling and heating.

8, 10 HP



12, 14, 16, 18, 20, 22 HP



24 - 44 HP



46 - 66 HP



68 - 88 HP



Duty Cycling

Duty cycling equalizes the running time of the outdoor units in a multiple-unit system and of the compressors in each unit, significantly extending compressor lifespan.



Backup

In a multi-unit system, if one module fails, the other modules provide backup so that the system can continue operating.



High EER and COP

DC compressors and fan motors together with a high-efficiency heat exchanger combine to give the Super Plus Series top-class energy efficiency in cooling and heating.

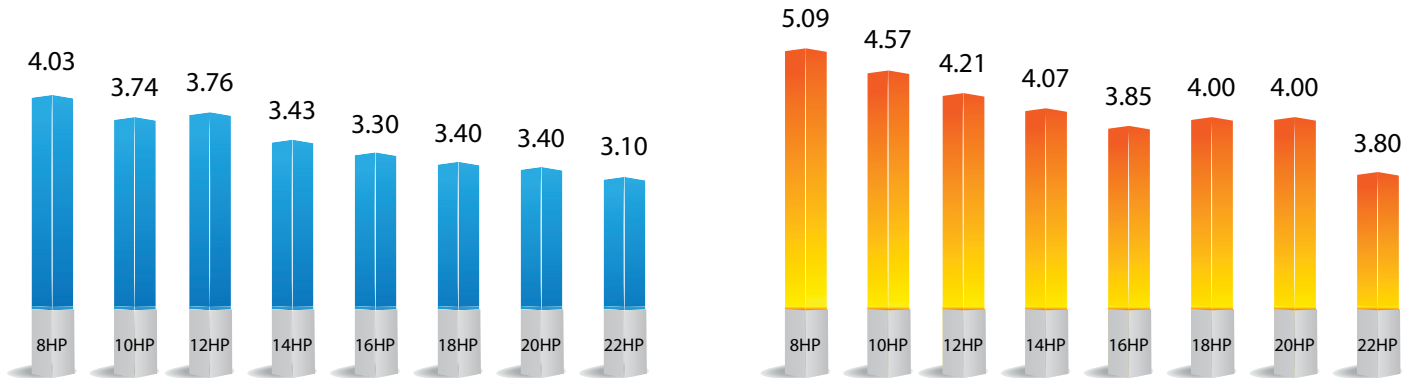

All DC Inverter Compressors

At the heart of the Super Plus Series outdoor unit lies a world-leading DC inverter scroll compressor. The compressor's innovative design and numerous high performance features reduce power consumption by 25%.



All DC Fan Motors

Fan speed is controlled according to the system pressure and system load, minimizing energy consumption.

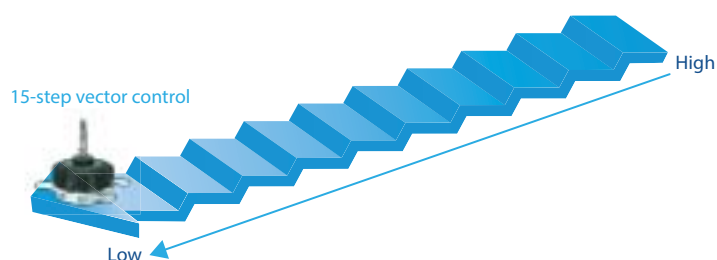

High Efficiency

High Efficiency Heat Exchanger

Newly designed fins enlarge the heat exchange area and decrease air resistance, enhance heat exchange performance and save more energy.

Hydrophilic fins and internally threaded copper pipes optimize heat exchange efficiency.

δ design increases the degree of liquefaction in the condenser and improves heat-exchange efficiency.

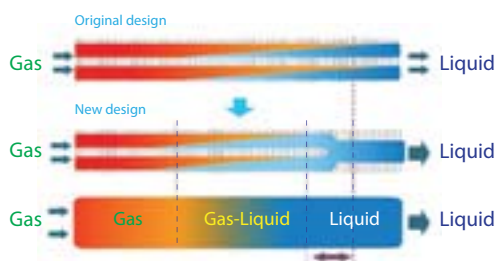
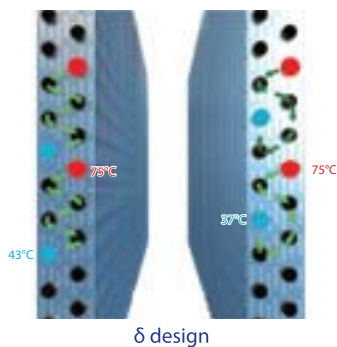
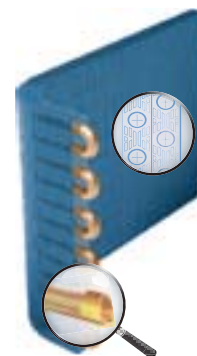

Long Piping Capability

Piping length	Capability
Total piping length	1000m
Longest length - actual (equivalent)	175m (200m)
Longest length after first branch	90m*
Largest height difference between indoor and outdoor units - ODU up (down)	90m (110m)
Largest height difference between indoor units	30m

*The longest length after first branch is 40m as standard but can be extended to up to 90m under certain conditions. Please contact your local Carrier sales companies for further information.

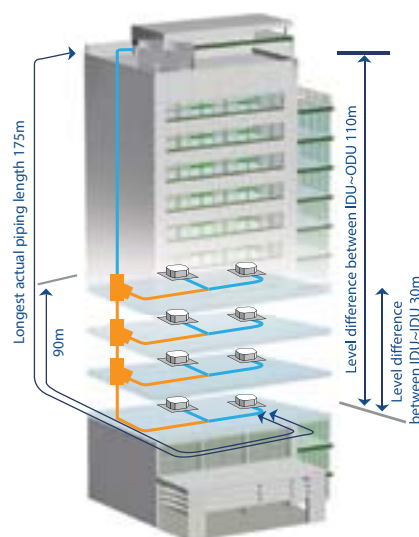

Intelligent Defrosting Technology

The intelligent defrosting program calculates the time required for defrosting according to the actual system status, eliminating heat losses from unnecessary defrosting. A specialized defrosting valve reduces time required for defrosting to as little as four minutes.

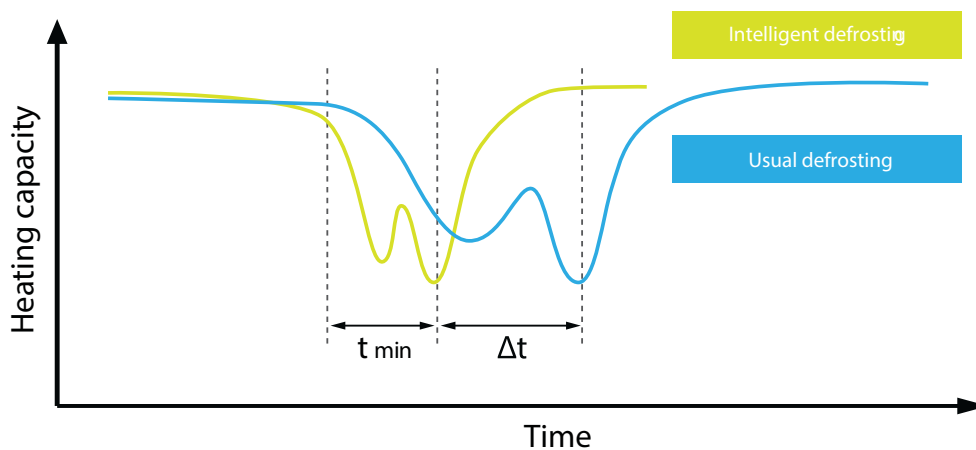

Rapid Cooling or Heating

The DC inverter compressor reaches full capacity rapidly, providing quicker cooling or heating with lower levels of temperature fluctuation during the cooling/heating operation.

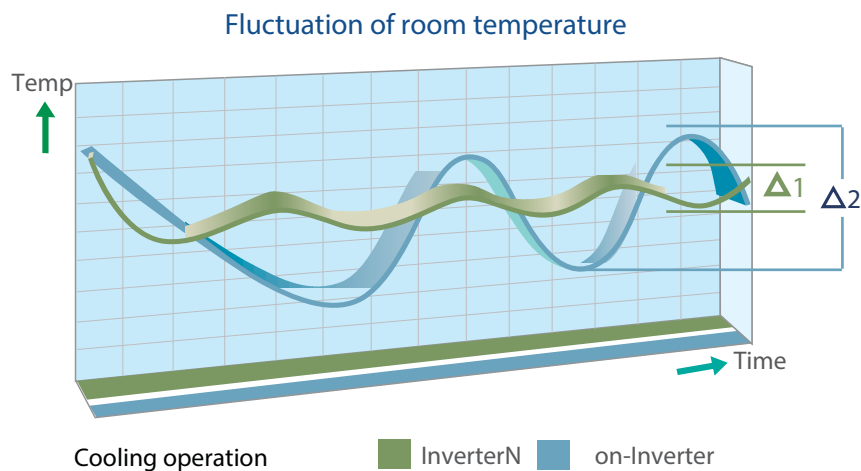

Features

Anti-corrosion Protection

Outdoor units are given anti-corrosion treatment for non-extreme conditions as standard and can also be customized with heavy anti-corrosion treatment on steel sheets, grills, coil fins, electric control box case and screws/bolts for surface protection against corrosive air, acid rain and saline air (for installations in coastal regions) to extend overall useful life.

The integrity of the anti-corrosion treatment is ensured by subjecting major components and parts to salt mist testing, moisture and heating testing and light aging testing.

Motor

Standard products:

- 72h of neutral salt mist

Heavy anti-corrosion products:

- 240h of neutral salt mist



Painted Sheet Metal

Standard products:

- 500h of neutral salt mist
- 1000h of moisture and heating test
- 500h of light aging test

Heavy anti-corrosion products:

- 1000h of neutral salt mist
- 2000h of moisture and heating test
- 720h of light aging test



Screws / Bolts / Gasket

Standard products:

- 300h of neutral salt mist

Heavy anti-corrosion products:

- 720h of neutral salt mist



Heat Exchanger Aluminum Foil

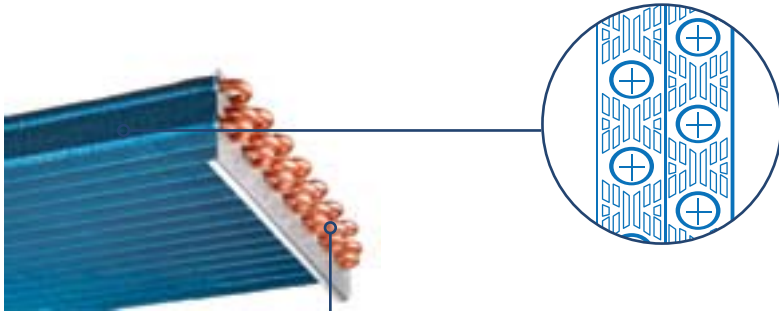

Standard products:

- 72h of neutral salt mist

Heavy anti-corrosion products:

- 1000h of neutral salt mist
- 140h of acid salt mist

Copper



Standard products:

- 24h of neutral salt mist

Heavy anti-corrosion products:

- 120h of neutral salt mist

Electric Control Box Case



Standard products:

- 96h of neutral salt mist

Heavy anti-corrosion products:

- 240h of neutral salt mist

Compressor / Motor Bolts

Standard products:

- 72h of neutral salt mist

Heavy anti-corrosion products:

- 168h of neutral salt mist



Specifications

8-14HP

Model			38VF008H11901E	38VF010H11901E	38VF012H11901E	38VF014H11901E
Power supply		V/Ph/Hz	380-415/3/50			
Cooling	Capacity	kW	25.2	28.0	33.5	40.0
	Power input	kW	6.25	7.49	8.91	11.66
	EER	kW/kW	4.03	3.74	3.76	3.43
	SEER	kW/kW	5.19	5.10	4.81	4.94
Heating	Capacity	kW	27.0	31.5	37.5	40.0
	Power input	kW	5.30	6.89	8.91	9.83
	COP	kW/kW	5.09	4.57	4.21	4.07
	SCOP	kW/kW	3.42	3.42	3.41	3.46
Connectable indoor unit	Total capacity	%	50~130% of outdoor unit capacity			
	Max. quantity		13	16	20	23
Sound pressure level		dB(A)	59	63	62	66
Pipe connections	Liquid pipe	mm	Φ12.7	Φ12.7	Φ15.9	Φ15.9
	Gas pipe	mm	Φ25.4	Φ25.4	Φ28.6	Φ31.8
	Oil balance pipe	mm	Φ8			
Fan motor	Type		DC motor			
	Quantity		1	1	1	2
	Air flow rate	m ³ /h	12000	12000	12000	14000
	ESP	Pa	0-20(0-0.08) (default)			
Pa		20-60(0.08-0.24) (customized)				
DC inverter compressor	Quantity		1	1	1	1
Refrigerant	Type		R410A	R410A	R410A	R410A
	Factory charging		9	9	11	13
Net dimension (W H D)		mm	990x1635x790	990x1635x790	990x1635x790	1340x1635x790
Packing size (W H D)		mm	1055x1805x855	1055x1805x855	1055x1805x855	1405x1805x855
Net weight		kg	219	219	237	297
Gross weight		kg	234	234	252	315
Operating	Cooling	°C	-5~48	-5~48	-5~48	-5~48
Temperature range	Heating	°C	-20~24	-20~24	-20~24	-20~24

Notes:

1. Indoor temperature 27°C DB, 19°C WB; outdoor temperature 35°C DB; equivalent refrigerant piping length 7.5m with zero level difference.
2. Indoor temperature 20°C DB; outdoor temperature 7°C DB, 6°C WB; equivalent refrigerant piping length 7.5m with zero level difference.
3. Diameters given are those of the unit's stop valve.
4. Sound pressure level is measured at a position 1m in front of the unit and 1.3m above the floor in a semi-anechoic chamber.
5. The data in this catalogue may be changed without notice for further improvement on quality and performance.

16-22HP

Model			38VF016H11901E	38VF018H11901E	38VF020H11901E	38VF022H11901E
Power supply		V/Ph/Hz	380-415/3/50			
Cooling	Capacity	kW	45.0	50.0	56.0	61.5
	Power input	kW	13.64	14.71	16.47	19.84
	EER	kW/kW	3.30	3.40	3.40	3.10
	SEER	kW/kW	4.89	4.94	4.93	4.77
Heating	Capacity	kW	45	50	56	61.5
	Power input	kW	11.69	12.5	14.0	16.18
	COP	kW/kW	3.85	4.0	4.0	3.80
	SCOP	kW/kW	3.46	3.42	3.40	3.40
Connectable indoor unit	Total capacity	%	50~130% of outdoor unit capacity			
	Max. quantity		26	29	33	36
Sound pressure level		dB(A)	66	66	66	66
Pipe connections	Liquid pipe	mm	Φ15.9	Φ15.9	Φ19.1	Φ19.1
	Gas pipe	mm	Φ31.8	Φ31.8	Φ31.8	Φ31.8
	Oil balance pipe	mm	Φ8			
Fan motor	Type		DC motor			
	Quantity		2	2	2	2
	Air flow rate	m ³ /h	14000	16000	16000	16000
	ESP	Pa	0-20(0-0.08) (default)			
		Pa	20-60(0.08-0.24) (customized)			
DC inverter compressor	Quantity		2	2	2	2
Refrigerant	Type		R410A	R410A	R410A	R410A
	Factory charging		13	13	16	16
Net dimension (W H D)		mm	1340x1635x790			
Packing size (W H D)		mm	1405x1805x855			
Net weight		kg	297	305	340	340
Gross weight		kg	315	323	358	358
Operating	Cooling	°C	-5~48	-5~48	-5~48	-5~48
Temperature range	Heating	°C	-20~24	-20~24	-20~24	-20~24

Notes:

1. Indoor temperature 27°C DB, 19°C WB; outdoor temperature 35°C DB; equivalent refrigerant piping length 7.5m with zero level difference.
2. Indoor temperature 20°C DB; outdoor temperature 7°C DB, 6°C WB; equivalent refrigerant piping length 7.5m with zero level difference.
3. Diameters given are those of the unit's stop valve.
4. Sound pressure level is measured at a position 1m in front of the unit and 1.3m above the floor in a semi-anechoic chamber.
5. The data in this catalogue may be changed without notice for further improvement on quality and performance.

Dimensions

38VF008H11901E / 38VF010H11901E / 38VF012H11901E

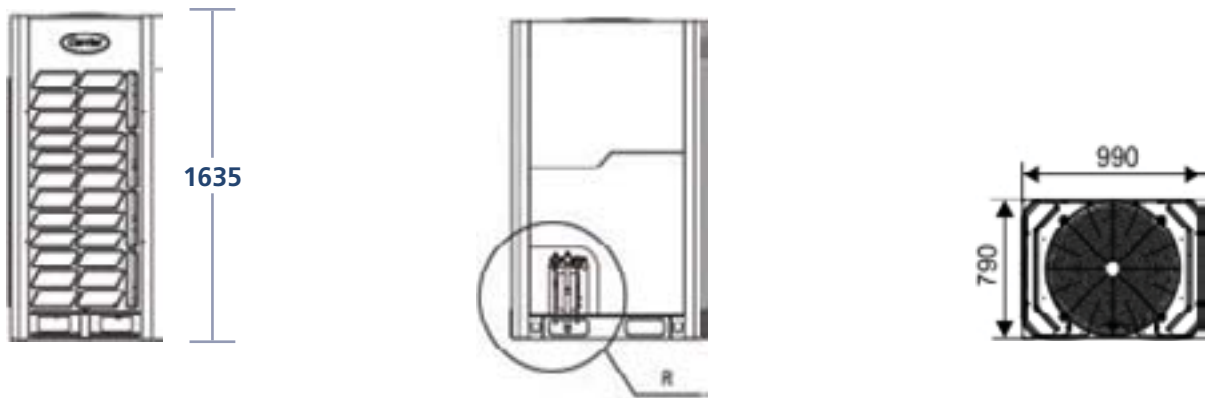

38VF014H11901E / 38VF016H11901E / 38VF018H11901E / 38VF020H11901E / 38VF022H11901E

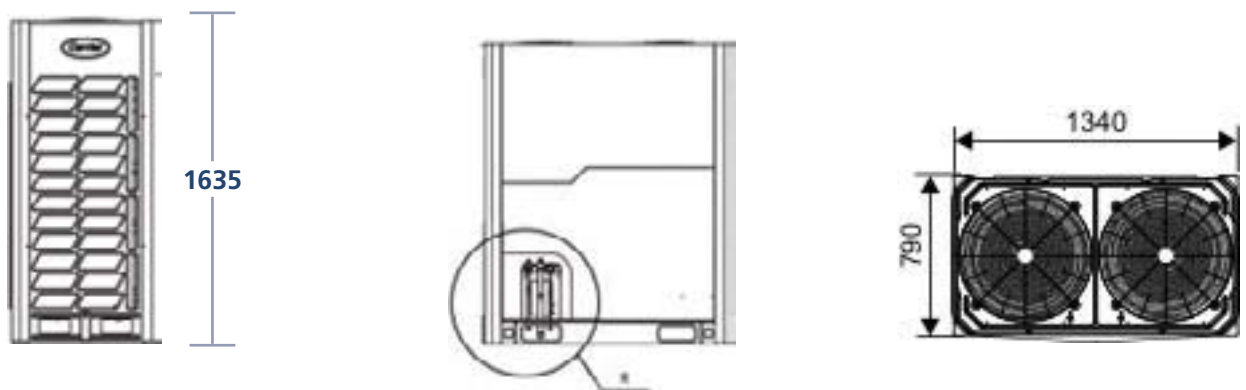

Installation Dimension

Single row installation (unit: mm)

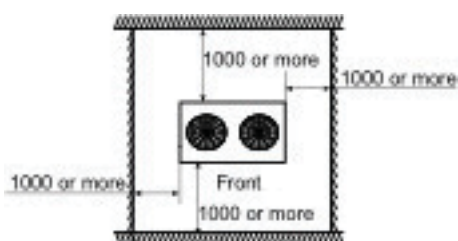

Single unit installation (unit: mm)

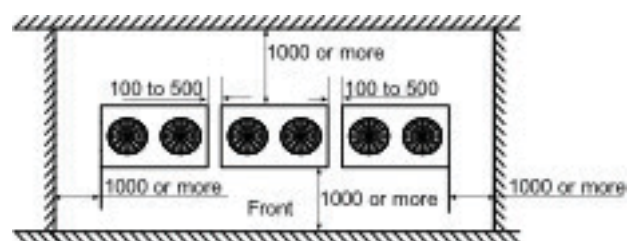



XPower Heat Recovery R Series

XPower Full DC Inverter R Series heat recovery can offer simultaneous cooling and heating operation in one system.

The energy by-product from cooling or heating is transferred to where it is required by using the balanced heat exchanger function, which saves up to 50% in costs compared with a conventional heat pump system.



- ALL DC inverter compressors
- ALL DC fan motors
- Capacity up to 64HP
- Connectable indoor units quantity up to 64
- ESP up to 60Pa
- Cycle duty operation
- Backup operation
- Precise oil control technology
- Advanced silence technology
- Simple communication wiring
- Remote addressing
- Easy maintenance



Indoor Units

Xpower VRF indoor unit



Ventilation

Heat recovery ventilator (HRV)



Control Systems

Smart control systems

Recommended combination table



Outdoor Unit Combination

Model	N° of Outdoor units	N° of Compressors	8	10	12	14	16	Maximum N° of Connectable Indoor Units	Capacity	
									Cooling	Heating
38VF008T11901E	1	1	1					13	25,2	27,0
38VF010T11901E	1	1		1				16	28,0	31,5
38VF012T11901E	1	1			1			20	33,5	37,5
38VF014T11901E	1	2				1		23	40,0	40,0
38VF016T11901E	1	2					1	26	45,0	45,0
38VF018T11901E	2	2	1	1				29	53,2	58,5
38VF020T11901E	2	2		2				33	56,0	63,0
38VF022T11901E	2	2		1	1			36	61,5	69,0
38VF024T11901E	2	3		1		1		39	68,0	71,5
38VF026T11901E	2	3		1			1	43	73,0	76,5
38VF028T11901E	2	4				2		46	80,0	80,0
38VF030T11901E	2	4				1	1	50	85,0	85,0
38VF032T11901E	2	4					2	53	90,0	90,0
38VF034T11901E	3	4		2		1		56	96,0	103,0
38VF036T11901E	3	4		2			1	59	101,0	108,0
38VF038T11901E	3	4		1	1		1	63	106,5	114,0
38VF040T11901E	3	5		1		1	1	64	113,0	116,5
38VF042T11901E	3	6				3		64	120,0	120,0
38VF044T11901E	3	6				2	1	64	125,0	125,0
38VF046T11901E	3	6				1	2	64	130,0	130,0
38VF048T11901E	3	6					3	64	135,0	135,0
38VF050T11901E	4	6	1	1			2	64	143,2	148,5
38VF052T11901E	4	6		2			2	64	146,0	153,0
38VF054T11901E	4	6		1	1		2	64	151,5	159,0
38VF056T11901E	4	7		1		1	2	64	158,0	161,5
38VF058T11901E	4	8				3	1	64	165,0	165,0
38VF060T11901E	4	8				2	2	64	170,0	170,0
38VF062T11901E	4	8				1	3	64	175,0	175,0
38VF064T11901E	4	8					4	64	180,0	180,0

Notes:

Capacities are based on the following conditions:
 Cooling: Indoor temperature 27°C DB/19°C WB; Outdoor temperature 35°C DB/24°C WB.
 Heating: Indoor temperature 20°C DB/15°C WB; Outdoor temperature 7°C DB/6°C WB.
 Piping length: Interconnecting piping length is 7,5m, level difference is zero.
 The above combination models are factory-recommended models.

Features

Wide range of outdoor units

The outdoor units capacity range from 8HP up to 64HP in 2HP increment. Maximum 64 indoor units with capacity up to 130% of total outdoor units can be connected in one refrigeration system.

8, 10, 12, 14 16HP



34 - 48HP

18-32HP



50 - 64HP



Long piping length

The solution supports an incredible piping length of 1.000m and level difference of 110m, making it perfect for large projects.

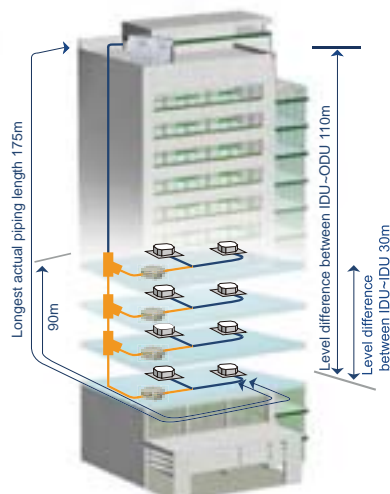

			Permitted value (m)
Piping length	Actual total piping length		1000*
	Longest piping	Actual length	175
		Equivalent length	200
	Equivalent piping length from the farthest IDU to the first indoor branch joint		40/90*
Equivalent piping length from MS to its downstream indoor unit		40	
Level difference	Level difference between indoor and outdoor units	Outdoor unit up	70
		Outdoor unit down	110
	Level difference between indoor units		30

*Total pipe length is equal to two times — pipe length plus — pipe length.

*When the piping length from the farthest IDU to the first indoor branch joint is more than 40m, it needs to meet specific conditions according to the installation part of the technical manual to achieve 90m.

Wide operation temperature range

It operates stably at extreme temperatures ranging from -20°C to 48°C.

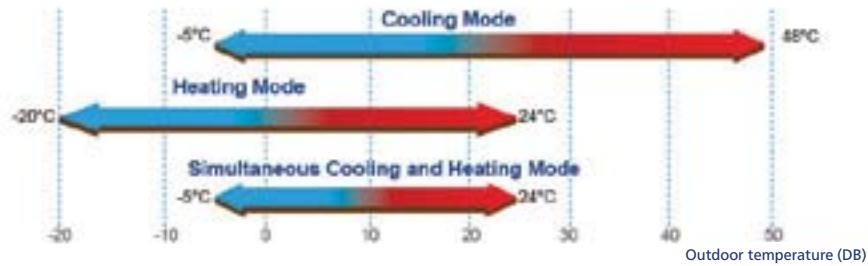

High external static pressure

Max. 60Pa external static pressure can be customized for the outdoor unit, flexible to build-in installation.

A standard 0-20Pa external static pressure is equipped by default for all outdoor units. 20-40Pa external static pressure can be customized for 14, 16HP outdoor units, and 20-60Pa can be customized for 8, 10, 12HP outdoor unit.



Features

All DC inverter technology

All DC inverter compressors make the capacity output better distributed, and always work at 60-140Hz which is the most efficient range. It makes the efficiency more than 30% higher than the normal.

All DC Inverter Compressor

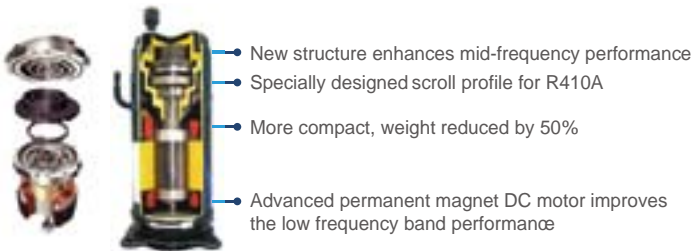

All DC Fan Motors

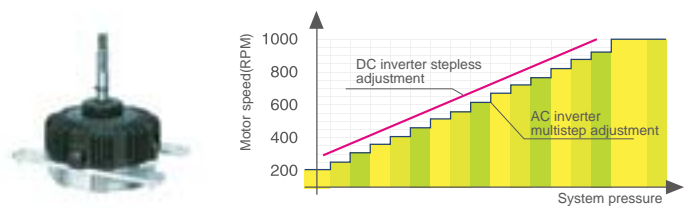

Heat recovery, more efficiency

Simultaneous heating and cooling in different zones, more energy saving by heat recovery from one space to another which saves up to 50% in costs compared with a conventional heat pump system.

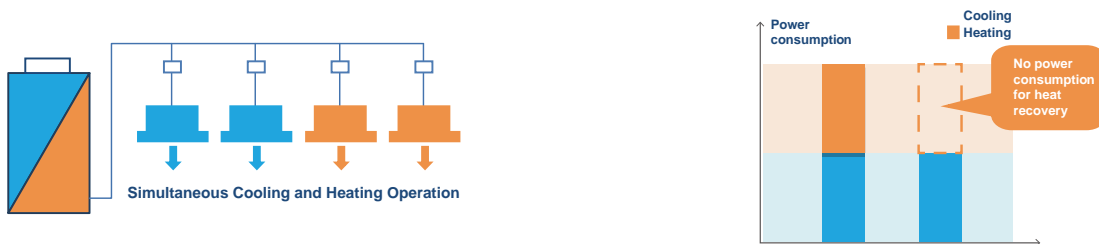

Heating capacity automatic adjustment

Two parts condenser individual design, the unit can distribute a part of evaporator to be as condensing area according to the heating load requirement to improve the utilization rate of the condenser.

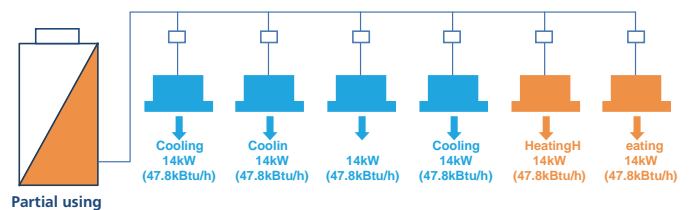

Cooling and heating simultaneous

Simultaneous cooling and heating achieved for new designed MS (Mode Switch) equipment.

The outdoor unit individual controls the operation mode of each group indoor unit to achieve simultaneous heating and cooling in one system under the MS equipment which adopts solenoid valve to precise control refrigerant flow rate.

The indoor units connect to the same MS can realize simultaneous cooling and heating operation.

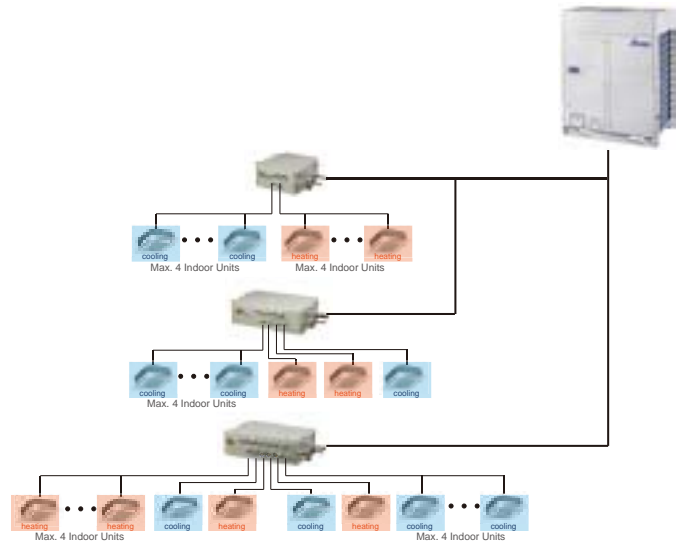

Silent mode control

Night silent operation will be activated X (6, 8) hours after the peak temperature during daytime, and it will get back to normal operation after Y (8,10,12) hours. To run in lower speed, lower noise, min. 46.8dB (A).

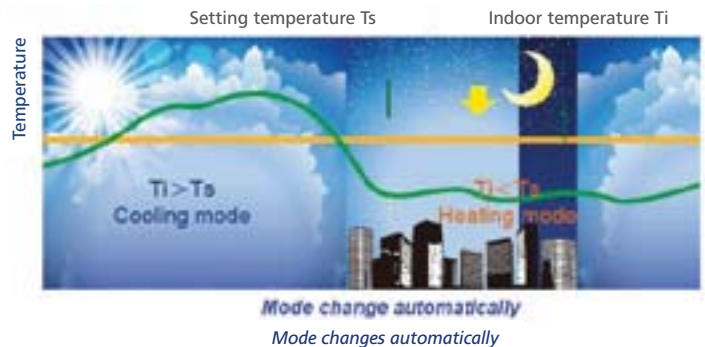

Continuous heating during defrost operation

is defrosted by using heat transferred from one heat exchanger to the other in the outdoor unit. Defrost has no impact on the indoor unit on heating mode.

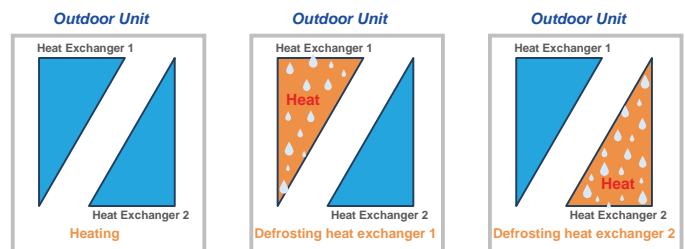

Features

Remote addressing

Addressing indoor units are able to be done just by pressing the button of the controller.

No need to set the address by the DIP switch one by one.

Wired controller and wireless controller can enquire and modify every indoor units address.



Simple communication wiring

Centralized controller (CCM03) can connect from indoor side or outdoor side (XYE terminals) at will. Only one group of communication wire of PQE, achieved both of communication for indoor & outdoor unit and network. It's more convenient for communication wiring.

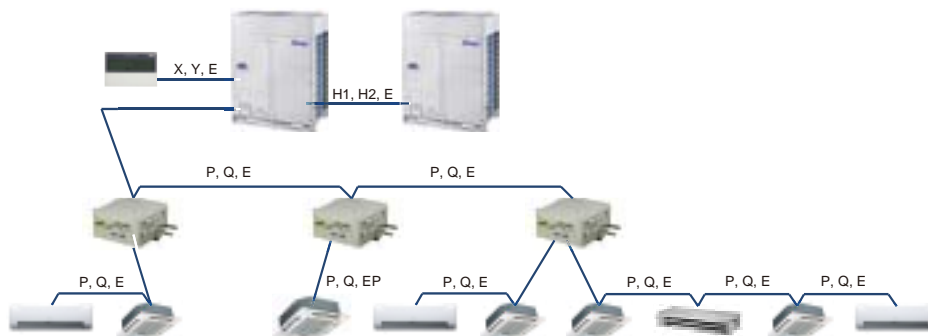

Professional structure design for easy maintenance

The check window reserved on electric control box provides a convenient spot checking and status enquiry.

With the 4 bits digital tube LED display, it is very convenient to show the data of the system, such as pressure, compressor frequency, error code, discharge temperature etc., which can make the maintenance, installation and commissioning easier.

Compressor is near the outside, and there is simple pipe system for convenient maintenance.

The newly designed rotating control box is so excellent that it can rotate in a wide angle.

It is convenient for the inspection and maintenance of the pipeline system and greatly reduced the time of dismount the electric control box.

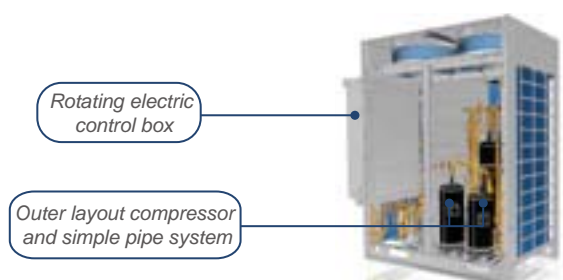

Specifications



Model			38VF008T11901E	38VF010T11901E	38VF012T11901E	38VF014T11901E	38VF016T11901E
Power supply		V/Ph/Hz	380-415/3/50				
Cooling	Capacity	kW	25,2	28,0	33,5	40,0	45,0
	Power input	kW	5,97	6,75	9,28	11,49	14,20
	EER	kW/kW	4,22	4,15	3,61	3,48	3,17
	SEER	kW/kW	4,78	4,84	4,65	4,72	4,62
Heating	Capacity	kW	27,0	31,5	37,5	40,0	45,0
	Power input	kW	5,02	6,21	9,24	9,76	11,90
	COP	kW/kW	5,38	5,07	4,06	4,10	3,78
	SCOP	kW/kW	3,41	3,41	3,41	3,45	3,45
Connectable indoor unit	Total capacity	%	50-130	50-130	50-130	50-130	50-130
	Max. quantity		13	16	20	23	26
Sound pressure level		dB(A)	59	62	63	66	66
Pipe connections	Liquid pipe	mm	Φ9,53	Φ12,7	Φ12,7	Φ15,9	Φ15,9
	Low pressure gas pipe	mm	Φ22,2	Φ22,2	Φ25,4	Φ28,6	Φ28,6
	High pressure gas pipe	mm	Φ19,1	Φ19,1	Φ19,1	Φ22,2	Φ22,2
	High pressure gas balance pipe	mm	Φ19,1	Φ19,1	Φ19,1	Φ19,1	Φ19,1
	Oil balance pipe	mm	Φ6,4	Φ6,4	Φ6,4	Φ6,4	Φ6,4
Fan motor	Type		DC	DC	DC	DC	DC
	Quantity		2	2	2	2	2
	Air flow rate	m ³ /h	12.000	12.000	13.000	15.000	15.000
	ESP	Pa	0-20 (default)			0-20 (default)	
Pa		20-40 (customized)		20-60 (customized)	20-40 (customized)		
DC inverter compressor	Quantity		1	1	1	2	2
Refrigerant	Type		R410A	R410A	R410A	R410A	R410A
	Factory charging	kg	10	10	10	13	13
Net dimension (WxHxD)		mm	1.250×1.615×765				
Packing size (WxHxD)		mm	1.305×1.790×820				
Net weight		kg	255	255	255	303	303
Gross weight		kg	273	273	273	322	322
Operating temperature range	Cooling	°C	-5-48				
	Heating	°C	-20-24				
	Simultaneous cooling and heating	°C	-5-24				

Notes:
 Capacities are based on the following conditions:
 Cooling: Indoor temperature 27°C DB/19°C WB; Outdoor temperature 35°C DB/24°C WB.
 Heating: Indoor temperature 20°C DB/15°C WB; Outdoor temperature 7°C DB/6°C WB.
 Piping length: Interconnecting piping length is 7,5m, level difference is 0m.
 Connection piping diameter is based on the condition that the total equivalent liquid length is less than 90m. When the total equivalent liquid length is more than 90m, please refer to technical manual to choose the connection piping diameter.
 Sound values are measured in a semi-anechoic room, at a position 1m in front of the unit and 1,3m above the floor.

Specifications

MS equipment which can be connected multiple indoor unit

Model			MSFT-01C-CM	MSFT-02C-CM	MSFT-04C-CM	MSFT-06C-CM	
Max. indoor unit groups			1	2	4	6	
Max. number of each group indoor units			4	4	4	4	
Max. number of all downstream indoor units			4×1=4	4×2=8	4×4=16	4×6=24	
Max. capacity of each group indoor units		kW	16	16	16	16	
Total capacity of all downstream indoor units		kW	≤16	≤28	≤45	≤45	
Piping connections	Connect to outdoor unit	Liquid pipe	mm	Φ9,53	Φ12,7	Φ15,9	Φ15,9
		High pressure gas pipe	mm	Φ15,9	Φ19,1	Φ22,2	Φ22,2
		Low pressure gas pipe	mm	Φ19,1	Φ25,4	Φ31,8	Φ31,8
	Connect to indoor unit	Liquid pipe	mm	Φ9,53	Φ9,53	Φ9,53	Φ9,53
		Gas pipe	mm	Φ15,9	Φ15,9	Φ15,9	Φ15,9
	Net dimension (W×H×D)		mm	630×225×600	630×225×600	960×225×600	960×225×600
Packing size (W×H×D)		mm	725×325×685	725×325×685	1055×325×685	1055×325×685	
Net weight		kg	18	19,5	31	35	
Gross weight		kg	25	27	40	44,5	
Sound pressure level (*1m below the MS box)		dB(A)	33	33	33	40	

MS equipment which can be connected only one indoor unit

Model			MSFT-02E-CM	MSFT-04E-CM	
Max. number of all downstream indoor units			1	1	
Capacity of downstream indoor unit		kW	20~28	40~56	
Piping connections	Connect to outdoor unit	Liquid pipe	mm	Φ12,7	Φ15,9
		High pressure gas pipe	mm	Φ19,1	Φ22,2
		Low pressure gas pipe	mm	Φ25,4	Φ31,8
	Connect to indoor unit	Liquid pipe	mm	Φ9,53	Φ9,53
		Gas pipe	mm	Φ15,9	Φ15,9
	Net dimension (W×H×D)		mm	630×225×600	960×225×600
Packing size (W×H×D)		mm	725×325×685	1055×325×685	
Net weight		kg	19,5	31	
Gross weight		kg	27	40	
Sound pressure level (measured 1m below the MS box)		dB(A)	33	33	

38VF008T119010/10/12/14/16

Body dimension

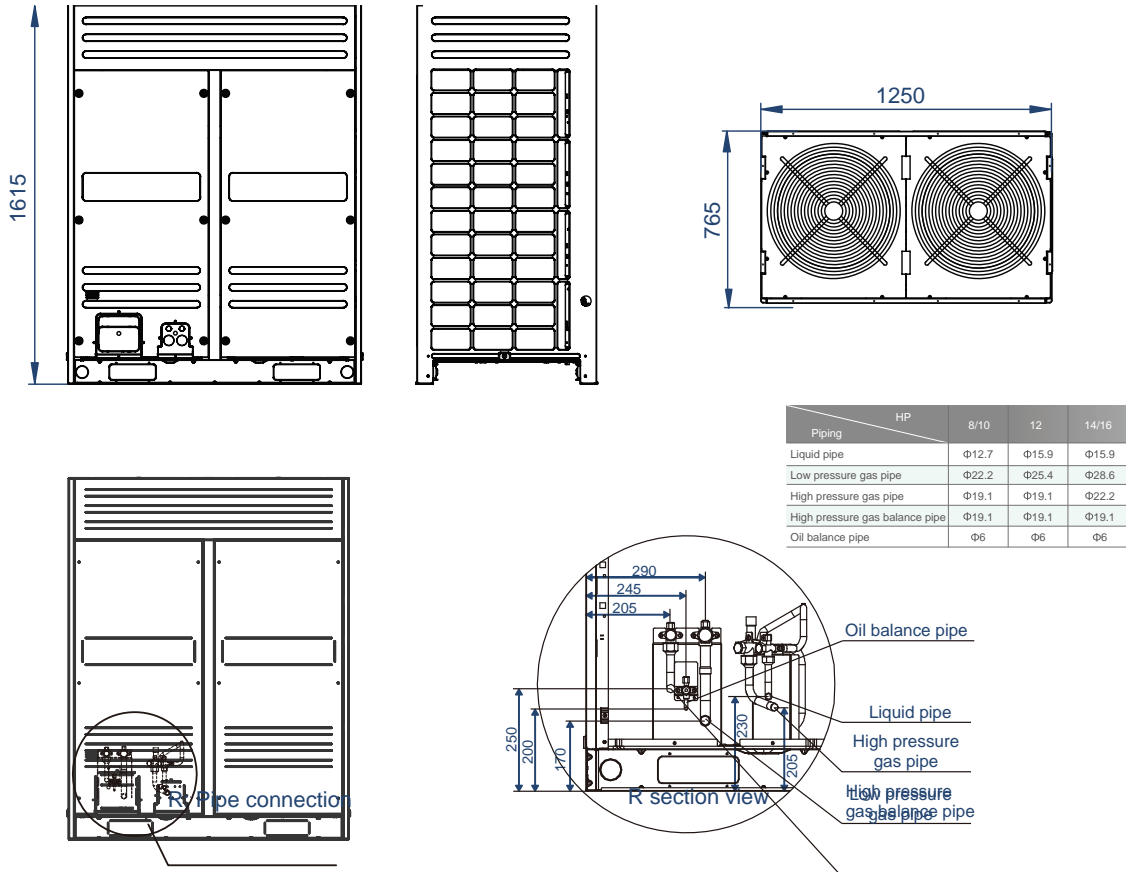

38VF008T119010/10/12/14/16

Installation dimension

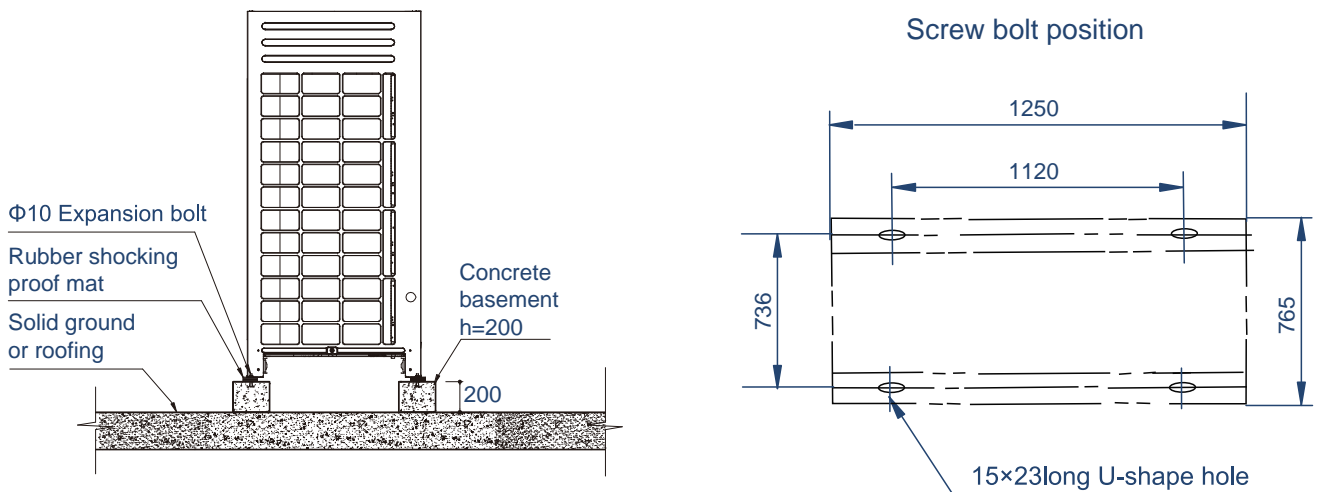

XPower Mini VRF Series

XPower Full DC Inverter Mini VRF with DC inverter compressor and DC fan motor delivers a highly efficient solution for small commercial buildings. Four to nine rooms require only one outdoor unit, and individual control is enabled in each room.



- DC inverter compressor
- DC fan motor
- Capacity up to 15,5kW
- Connectable indoor units quantity up to 7
- Precise oil control technology
- Advanced silence technology
- Intelligent defrosting technology
- Simple communication wiring
- Auto addressing
- Easy maintenance
- Eurover Certified



Indoor Units

Xpower VRF indoor unit



Ventilation

Heat recovery ventilator (HRV)



Control Systems

Smart control systems



Wide range of outdoor units

The capacity range of outdoor unit is from 12kW to 15,5kW with three models and two air-discharge type.

Maximum connectable up to 7 indoor units with capacity up to 130% of total outdoor units can be connected in one refrigeration system.

12,3/14/15,5 kW



Flexible indoor units connection

Mini VRF with intelligent control gives you independent zoning control with maximum flexibility. A single outdoor unit supports up to nine indoor units, freeing up considerable space outside. Use your backyard more wisely with much more space available created by less number of outdoor units.

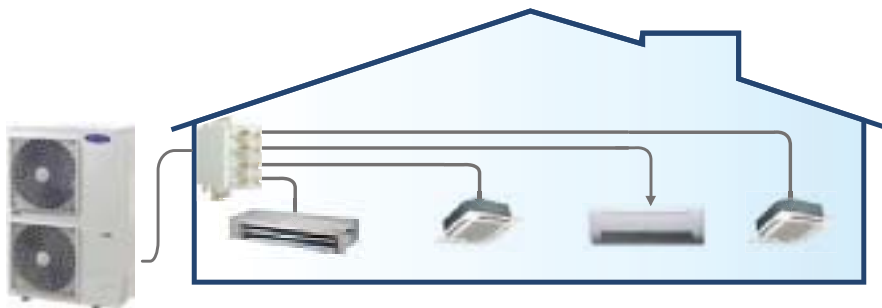

Features

Long piping length

The Mini VRF provides a total piping length possibility of 100m, a maximum height difference between outdoor and indoor units of 30m. The height difference between indoors unit can be up to 8m. These generous allowances facilitate an extensive array of system designs.

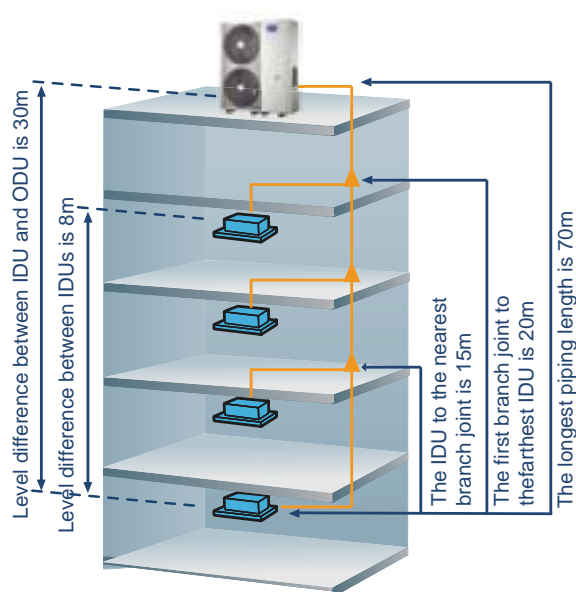

		Permitted value (m)	
		12/14/16/18kW	
Piping length	Actual total piping length*1		100
	Longest piping	Actual length	60
		Equivalent length	70
	Equivalent piping length from the farthest IDU to the first indoor branch joint		20
Level difference	Level difference between indoor and outdoor units	Outdoor unit up	30
		Outdoor unit down	20
	Level difference between indoor units		8

*1: Total pipe length is equal to all the liquid pipe or all the gas pipe length.

Easy Installation

Easy installation:
No special area is required for outdoor units.

Easy transportation:
All outdoor units can be transported by elevator, which greatly simplifies installation and reduces time and labour.

The Mini VRF indoor and outdoor units are almost as easy to install as residential air conditioning systems, making them ideal for small offices and shops.

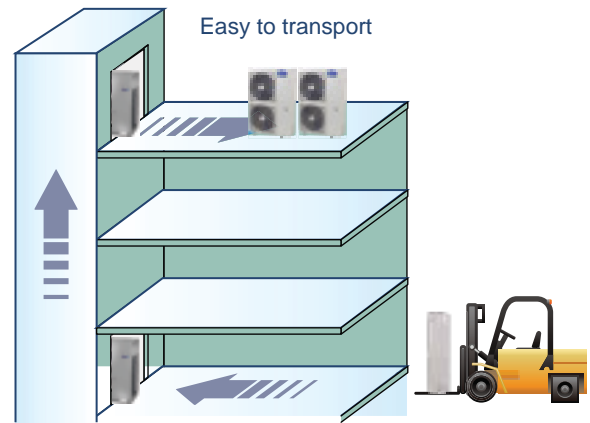

Space saving design

The Mini VRF units are slimmer and more compact, resulting in significant savings in installation space. In some large residential and light commercial areas, such as villas, restaurants, usually it need more than one indoor unit, which in turn requires multiple outdoor units. Mini VRF system removes this problem, and retains buildings' original aesthetics.

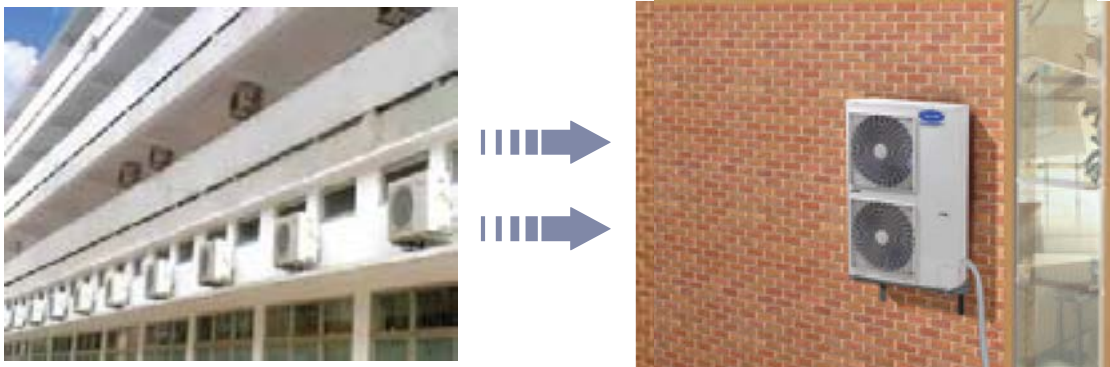

Auto addressing

Addresses of indoor units can be set automatically by outdoor units. Wireless controller can inquire and modify every indoor units address.

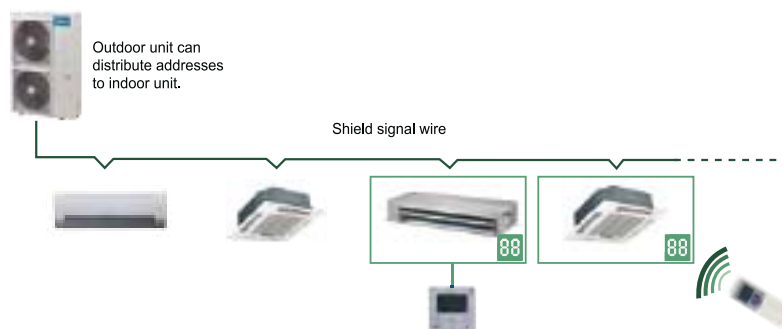

Features

More convenience in installation

A four-direction space is available for connecting pipes and wiring in various installation sites.

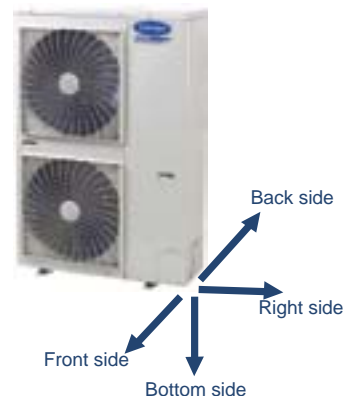
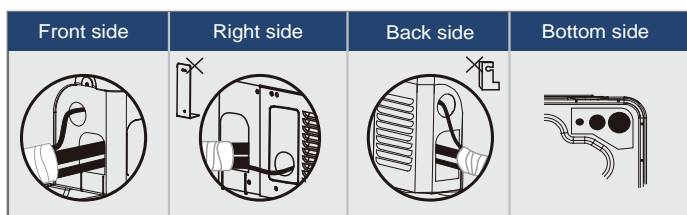

More convenient piping connector - branch box

Easier and safer installation thanks to a branch box that simplifies piping work and the adoption of screw connection. Both left and right pipe flare connection from outdoor unit to branch box is reserved, which greatly simplifies field installation. Two sets of pipe size converter are packed with branch box to transfer the pipe size from $\Phi 6,35\text{mm}$ to $\Phi 9,53\text{mm}$ and from $\Phi 12,7\text{mm}$ to $\Phi 15,9\text{mm}$.

Low noise

The branch pipe is linear expansion design regulates the flow of refrigerant and reduces the noise. By locating the branch box in the ceiling or outside, noise generated by the branch box can be kept clear of living spaces, thus makes noise level to a minimum.

Brazing-free quick installation

All the piping leading to and from the branch box is connected using screw joints, which can be installed quickly and easily.

Indoor installation

The branch box can be installed in the ceiling rather than outside. Removing the side and bottom covers provides easy access for maintaining inner components such as circuit boards.



More convenience in installation

A four-direction space is available for connecting pipes and wiring in various installation sites.

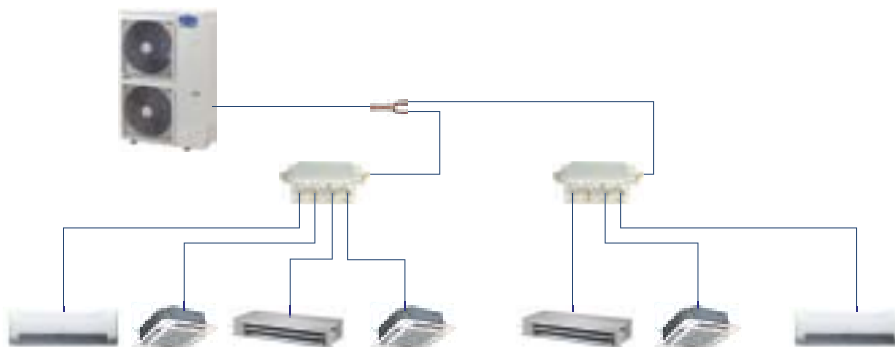

Full DC inverter technology

At the heart of our system is a highly intelligent inverter driven compressor. This advanced technology enables the output of the outdoor unit to be modulated by the cooling or heating demands of the zone that it controls. This advanced system ensures precise temperature regulation and highly efficient energy usage, making a significant contribution to the limiting the impact on the environment.

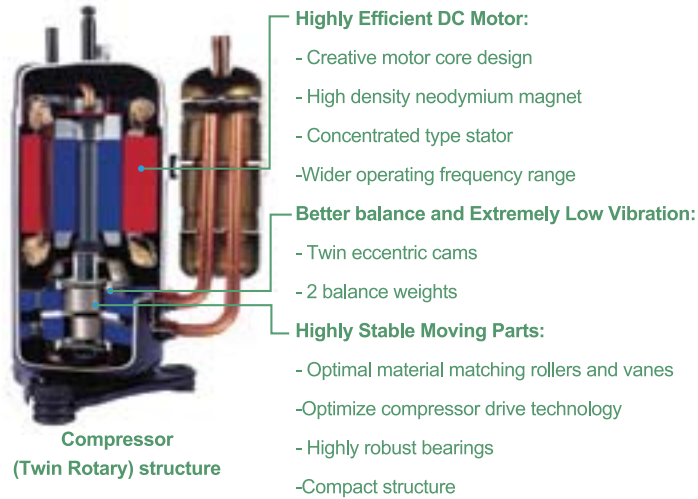

High efficiency DC fan motor saved power up to 50%.

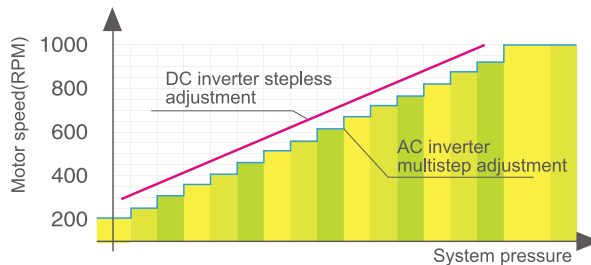

Noise reducing design

Optimally designed fan shape and air discharge grille increases air volume and reduces running noise.

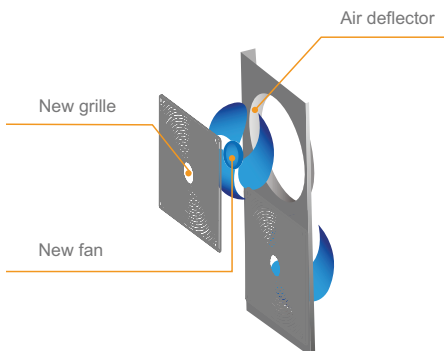

Newly Designed Fan Guard

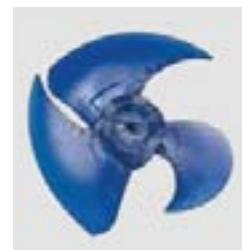

Powerful Large Propeller

Specifications

Model			38VR004H11201E	38VR005H11201E	38VR006H11201E	38VR004H11901E	38VR005H11901E	38VR006H11901E
Power supply		V/Ph/Hz	220-240/1/50			380-415/3/50		
Cooling	Capacity	kW	12,3	14.0	15.5	12.3	14.0	15.5
	Input	kW	3.25	3.95	4.52	3.25	3.95	4.52
	EER	kW/kW	3.78	3.54	3.43	3.78	3.54	3.43
	SEER	kW/kW	5.67	5.92	6.05	5.67	5.92	6.05
Heating	Capacity	kW	13.2	15.4	17.0	13.2	15.4	17.0
	Input	kW	3.47	4.16	4.77	3.47	4.16	4.77
	COP	kW/kW	3.80	3.70	3.56	3.80	3.70	3.56
	SCOP	kW/kW	3.9	3.86	3.04	3.9	3.86	3.04
Connectable indoor unit	Total capacity	%	45-130	45-130	45-130	45-130	45-130	45-130
	Max. quantity		6	6	7	6	6	7
Sound pressure level		dB(A)	57	57	57	57	57	57
Pipe connections	Liquid pipe	mm	Φ9.53	Φ9.53	Φ9.53	Φ9.53	Φ9.53	Φ9.53
	Gas pipe	mm	Φ15.9	Φ15.9	Φ19.1	Φ15.9	Φ15.9	Φ19.1
Fan motor	Type		DC	DC	DC	DC	DC	DC
	Quantity		2	2	2	2	2	2
	Air flow rate	m ³ /h	6.000	6.000	6.000	6.000	6.000	6.000
Rotary compressor	Quantity		1	1	1	1	1	1
Refrigerant	Type		R410A	R410A	R410A	R410A	R410A	R410A
	Factory charging	kg	3.3	3.9	3.9	3.3	3.9	3.9
Net dimension (WxHxD)		mm	900x1.327x400			900x1.327x400		
Packing size (WxHxD)		mm	1.030x1.456x435			1.030x1.456x435		
Net weight		kg	95	95	100	95	95	102
Gross weight		kg	106	106	111	106	106	113
Operating temperature range	Cooling	°C	-15~43					
	Heating	°C	-15~27					

Notes:

Capacities are based on the following conditions:

Cooling: Indoor temperature 27°C DB/19°C WB; Outdoor temperature 35°C DB/24°C WB.

Heating: Indoor temperature 20°C DB/15°C WB; Outdoor temperature 7°C DB/6°C WB.

Piping length: Interconnecting piping length is 5m, level difference is 0m.

Sound values are measured in a semi-anechoic room, at a position 1m in front of the unit and 1m above the floor.

2010: When the * is omit, the model stands for 220-240V/1ph/50Hz unit.

9010: When the * is R, the model stands for 380-415V/3ph/50Hz unit.

38VR004/005/006H11201E

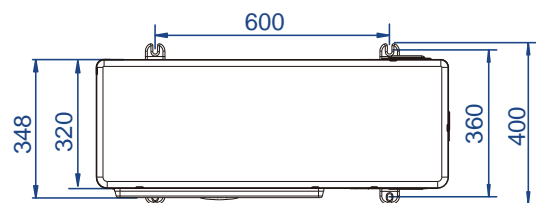
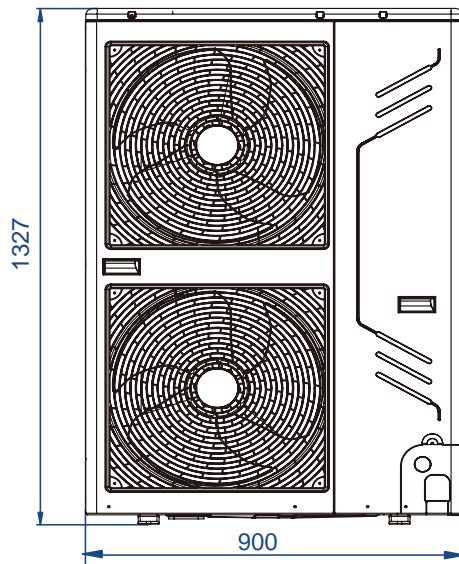

XPower Mini VRF / Side Discharge

XPower Full DC Inverter Mini VRF / Side Discharge it is designed to optimize performance and better match varieties of application requirement. It is focused on providing better air solutions for the small and middle-sized buildings.



- DC inverter compressor
- DC fan motor
- Capacity up to 45kW
- Connectable indoor units quantity up to 15
- Precise oil control technology
- Advanced silence technology
- Intelligent defrosting technology
- Simple communication wiring
- Auto addressing
- Easy maintenance



Indoor Units
Xpower VRF indoor unit



Ventilation
Heat recovery ventilator (HRV)



Control Systems
Smart control systems

Wide range of outdoor units

The capacity range of outdoor unit is from 22.4kW to 45kW with four models side air-discharge type.

Maximum 15 indoor units with capacity up to 130% of total outdoor units can be connected in one refrigeration system.

20/22.4/26 kW



40/45 kW



Wide operation range

It operates stably at extreme temperatures ranging from -15°C to 48°C.

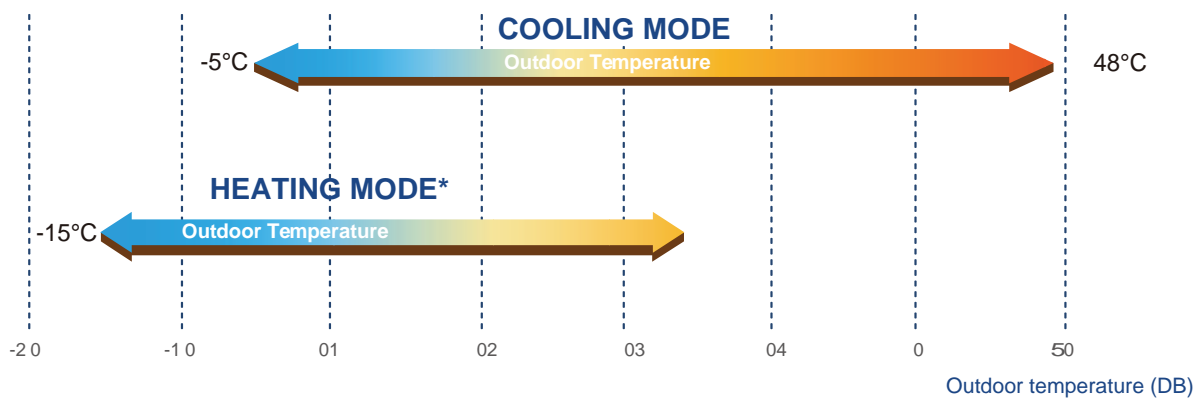

Features

Long piping length

The Mini VRF provides a total piping length possibility of 100m, a maximum height difference between outdoor and indoor units of 30m. The height difference between indoors unit can be up to 8m. These generous allowances facilitate an extensive array of system designs.

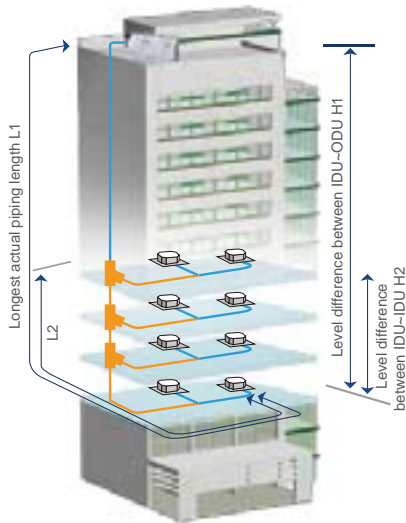

		Permitted value		
		20-26kW	40-45kW	
Piping length	Total piping length (Actual)	120	250	
	Longest piping	Actual length	60	100
		Equivalent length	70	120
	Equivalent piping length from the farthest IDU to the first indoor branch joint	20	40	
Level difference	Level difference between IDU-ODU	Outdoor unit up	30	30
		Outdoor unit down	20	20
	Level difference between IDU-IDU	8	8	

*1: Total pipe length is equal to two times orange pipe length plus blue pipe length.

*2: When the piping length from the farthest IDU to the first indoor branch joint is more than 40m, it needs to meet specific conditions according to the installation part of the technical manual to achieve 90m.

High efficiency and energy-saving

Carrier VRF realized the industry's top class energy efficiency by adoption of Brushless Reluctance DC compressor control, All DC fan motor and improved heat exchanger.

High efficiency DC inverter compressor, saving power 25%

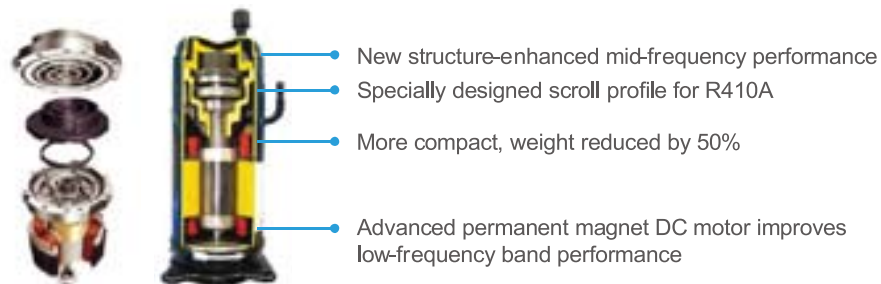

High efficiency DC fan motor, saving power 50%

According to the running load and pressure, it controls the speed of DC fan to achieve the minimum energy consumption, to reach the best effect. Used across entire range of models (from 8 to 72HP). Efficiency improved up to 45% especially at low speed.

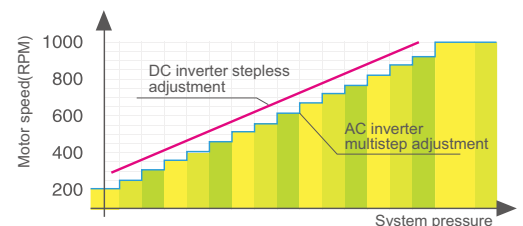

The fluctuation range of motor rotor speed is within ± 5 rpm and the motor can rapidly match the output of DC inverter compressor. The efficiency is enhanced under part load.

Optimized fan shape and fan grille

Optimized fan blade shape with new air outlet grille enhanced air flow volume which greatly improves fan performance and decreases noise.

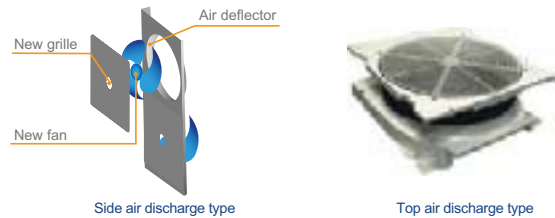

Optimize heat exchange design, heat exchange efficiency increased by 10%

12°C sub-cooling degree makes the cooling capacity increased efficiently. Innovative designed outdoor high efficiency heat exchanger can reach up to 12°C sub-cooling degree one time, reduces the system resistance and improves reliability.



Intelligent defrosting technology

Intelligent defrosting program will judge the defrosting time according to the system real requirement, reduce the heating loss by unnecessary defrosting and make the indoor side more comfortable.

Defrosting time can be shortened to 4 min. due to the specialized defrosting valve.

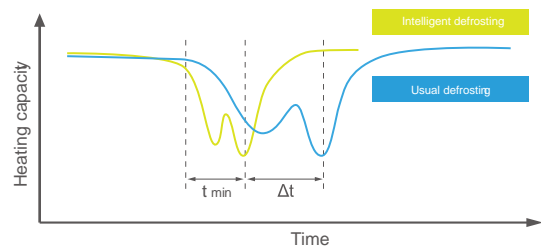

Features

Easy Installation

Easy installation: No special area is required for outdoor units.

Easy transportation: All outdoor units can be transported by elevator, which greatly simplifies installation and reduces time and labor.

The Mini VRF indoor and outdoor units are almost as easy to install as residential air conditioning systems, making them ideal for small offices and shops.

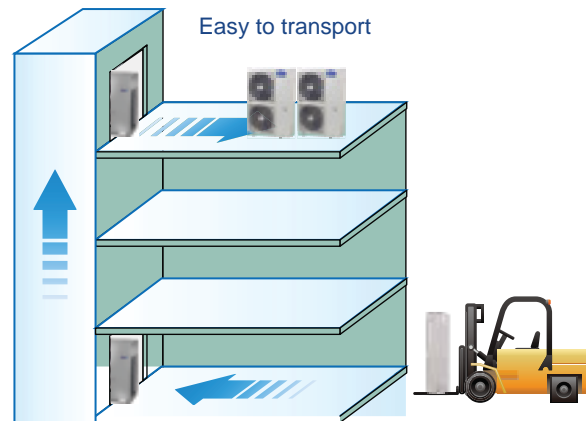

Space saving design

The Mini VRF units are slimmer and more compact, resulting in significant savings in installation space.

In some large residential and light commercial areas, such as villas, restaurants, usually it need more than one indoor unit, which in turn requires multiple outdoor units.

Mini VRF system removes this problem, and retains buildings' original aesthetics.



Auto addressing

Addresses of indoor units can be set automatically by outdoor units.

Wireless controller can inquire and modify every indoor units address.

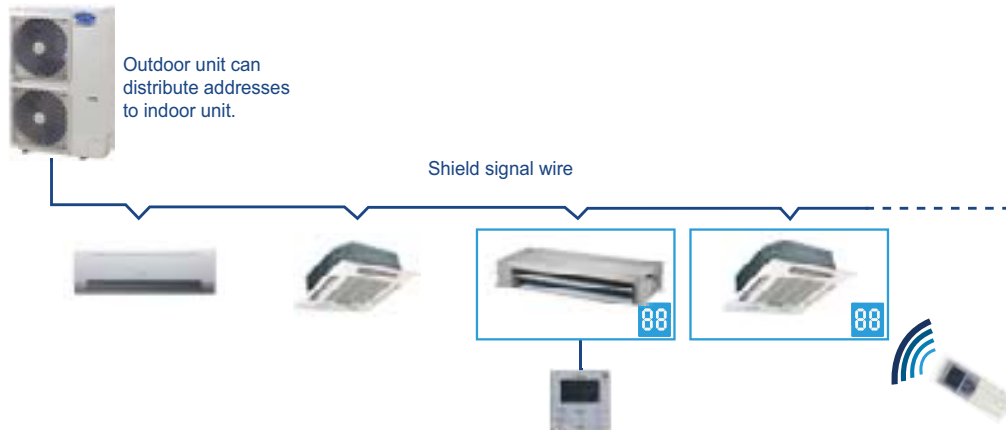

Easy piping connection

The side out discharge type offering four-directions to connect pipes and wirings for meet a variety installation request.

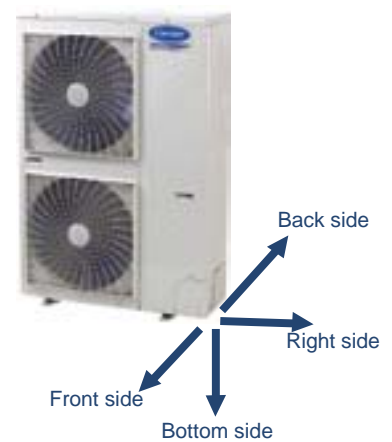
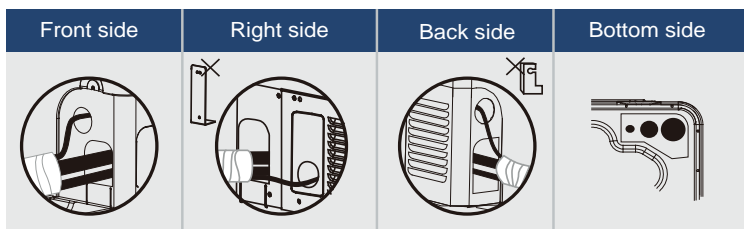

Specifications

Model			38VR008H11901S	38VR010H11901S	38VR014H119012	38VR016H119012
Power supply		V/Ph/Hz	380-415/3/50			
Cooling	Capacity	kW	22,4	26,0	40,0	45,0
	Power input	kW	7,2	8,4	11,9	13,6
	EER	kW/kW	3,11	3,09	3,35	3,32
	SEER	kW/kW	6,07	5,43	5,08	5,03
Heating	Capacity	kW	24,5	28,5	45,0	50,0
	Power input	kW	6,7	7,9	11,1	12,7
	COP	kW/kW	3,66	3,61	4,05	3,93
	SCOP	kW/kW	3,74	3,76	3,51	3,46
Connectable indoor unit	Total capacity	%	50-130	50-130	50-130	50-130
	Max. quantity		11	12	14	15
Sound pressure level		dB(A)	59	60	62	62
Pipe connections	Liquid pipe	mm	Φ9,53	Φ9,53	Φ12,7	Φ12,7
	Gas pipe	mm	Φ19,1	Φ22,2	Φ22,2	Φ25,4
Fan motor	Type		DC		DC	
	Quantity		2		2	
	Air flow rate	m ³ /h	10.494	10.494	16.575	16.575
Rotary compressor	Quantity		1	1	2	2
Refrigerant	Type		R410A	R410A	R410A	R410A
	Factory charging	kg	6,2	6,2	9	12
Net dimension (WxHxD)		mm	1.120x1.558x528		1360x1650x540	1460x1650x540
Packing size (WxHxD)		mm	1.270x1.720x565		1450x1785x560	1550x1785x560
Net weight		kg	146,5	147	240	275
Gross weight		kg	162,5	163	260	290
Operating temperature range	Cooling	°C	-15~46		-5~48	
	Heating	°C	-15~24		-15~24	

Notes:

Capacities are based on the following conditions:

Cooling: Indoor temperature 27°C DB/19°C WB; Outdoor temperature 35°C DB/24°C WB.

Heating: Indoor temperature 20°C DB/15°C WB; Outdoor temperature 7°C DB/6°C WB.

Piping length: Interconnecting piping length is 7,5m, level difference is 0m.

Sound values are measured in a semi-anechoic room, at a position 1m in front of the unit and 1,3m above the floor.

38VR008/010H11901S

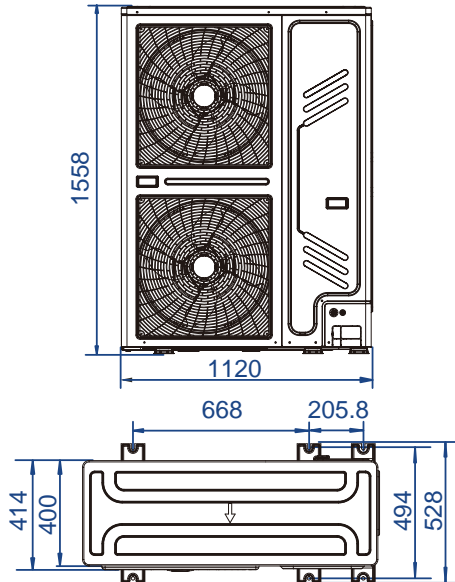

38VR014/016H119012

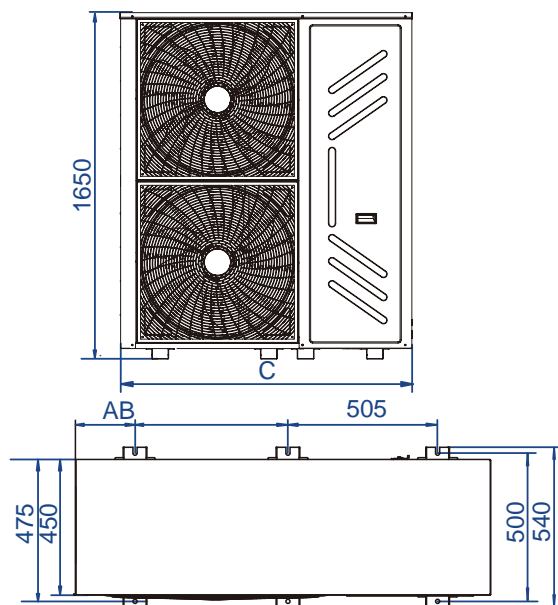

Size Model	AB		C
40kW	175	505	1360
45kW	225	555	1460





Indoor Units

Cassettes

One-way Cassette



- Auto Restart Function
- Auto Addressing
- Fresh Air
- Auto Defrosting
- Easy-cleaning Panel
- Follow Me
- Anti-cold Air Function
- Built-in Drain Pump
- LED Display
- Built-in Filter
- Independent Dehumidification
- Timer
- Auto Swing
- Wired Controller

Only 153mm high

The slim, compact design make the One-way Cassette ideal for interiors with limited ceiling space. Models 18 to 36 are just 153mm high whilst models 45 to 71 are 189mm high.

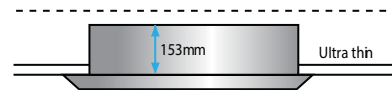

High-lift Drain Pump

A drain pump with a 750mm pump head is fitted as standard.

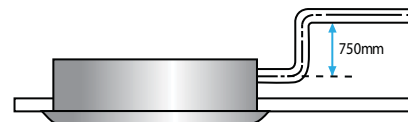

Fresh Air Intake

A reserved outside air intake port allows outdoor air to be introduced directly into the unit, negating the need for a separate ventilation system.



Specifications



Model			40VZ009H11200011	40VZ012H11200011	40VZ018H11200011	40VZ024H11200011	40VZ028H11200011
Power supply			1-phase,220-240V,50Hz				
Capacity	Cooling	kW	2.8	3.6	4.5	5.6	7.1
	Heating	kW	3.2	4.0	5.0	6.3	8.0
Power input	Cooling	W	41	41	48	48	60
	Heating	W	41	41	43	44	55
Airflow rate(H/M/L)		m ³ /h	573/456/315	573/456/315	693/600/476	792/688/549	933/749/592
Sound pressure level(H/M/L)		dB(A)	39/37/34	40/38/34	41/39/35	42/40/36	44/41/37
Main body	Net dim.(WxHxD)	mm	1054x153x425	1054x153x425	1275x189x450	1275x189x450	1275x189x450
	Net/gross weight	kg	13/16.5	13/16.5	18.5/22.8	18.8/23.1	19.5/23.8
Panel	Net dim.(WxHxD)	mm	1180x25x465	1180x25x465	1350x25x505	1350x25x505	1350x25x505
	Net/gross weight	kg	3.5/5.2	3.5/5.2	4/5.4	4/5.4	4/5.4
Piping connections	Liquid/gas pipe	mm	Φ6.35/Φ12.7	Φ6.35/Φ12.7	Φ6.35/Φ12.7	Φ9.53/Φ15.9	Φ9.53/Φ15.9
	Drain pipe	mm	OD Φ25	OD Φ25	OD Φ25	OD Φ25	OD Φ25
Standard controller			Wireless remote controller				
Decoration Panel			40VZ00A00/2		40VZ00A01		

Notes:

1. Nominal capacities are based on the following conditions:

- Cooling: indoor temperature 27°C DB, 19°C WB; outdoor temperature 35°C DB; equivalent refrigerant piping length 7.5m with zero level difference.
- Heating: indoor temperature 20°C DB; outdoor temperature 7°C DB, 6°C WB, equivalent refrigerant piping length 7.5m with zero level difference.

2. Sound pressure level is measured 1.4m below the unit in a semi-anechoic chamber.

Two-way Cassette



- Auto Restart Function
- Auto Addressing
- Fresh Air
- Auto Defrosting
- Easy-cleaning Panel
- Follow Me
- Anti-cold Air Function
- Built-in Drain Pump
- LED Display
- Built-in Filter
- Independent Dehumidification
- Timer
- Auto Swing
- Wired Controller

Low Sound Level

The Two-way Cassette's optimized, low resistance air outlets reduce noise levels to as low as 24dB(A).

Stylish Design and Slim Body

A stylish design and slim body make the Two-way Cassette suited to any room's decor and ambience. At only 300mm high, it can be installed in most ceiling spaces.

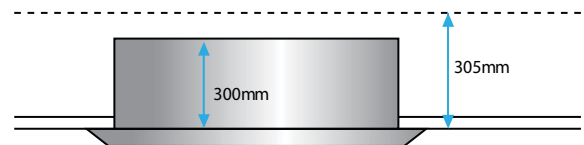

High-lift Drain Pump

A drain pump with a 750mm pump head is fitted as standard, simplifying installation of the drain piping. Higher pump heads are available as a customization option.

High Airflow

A high airflow rate ensures even airflow and temperature throughout the room, even in high ceiling installations.



Specifications



Model			40VT009H10200010	40VT012H10200010	40VT018H10200010	40VT024H10200010	40VT028H10200010
Power supply			1-phase,220-240V,50Hz				
Capacity	Cooling	kW	2.8	3.6	4.5	5.6	7.1
	Heating	kW	3.2	4.0	5.0	6.3	8.0
Power input	Cooling	W	57	60	92	108	154
	Heating	W	57	60	92	108	154
Airflow rate(H/M/L)		m ³ /h	654/530/410	725/591/458	850/670/550	980/800/670	1,200/1,000/770
Sound pressure level(H/M/L)		dB(A)	36/32/29	36/32/29	39/35/30	39/35/30	44/40/34
Main body	Net dim.(WxHxD)	mm	1172x299x591	1172x299x591	1172x299x591	1172x299x591	1172x299x591
	Net/gross weight	kg	34/42.5	34/42.5	36/44.5	36/44.5	36/44.5
Panel	Net dim.(WxHxD)	mm	1430x53x680	1430x53x680	1430x53x680	1430x53x680	1430x53x680
	Net/gross weight	kg	10.5/15	10.5/15	10.5/15	10.5/15	10.5/15
Piping connections	Liquid/gas pipe	mm	Φ6.35/Φ12.7	Φ6.35/Φ12.7	Φ6.35/Φ12.7	Φ9.53/Φ15.9	Φ9.53/Φ15.9
	Drain pipe	mm	OD Φ32	OD Φ32	OD Φ32	OD Φ32	OD Φ32
Standard controller			Wireless remote controller				
Decoration Panel			40VT00A00				

Notes:

1. Nominal capacities are based on the following conditions:

- Cooling: indoor temperature 27°C DB, 19°C WB; outdoor temperature 35°C DB; equivalent refrigerant piping length 7.5m with zero level difference.
- Heating: indoor temperature 20°C DB; outdoor temperature 7°C DB, 6°C WB; equivalent refrigerant piping length 7.5m with zero level difference.

2. Sound pressure level is measured 1.4m below the unit in a semi-anechoic chamber.

Four-way Cassette



- Auto Restart Function
- Auto Addressing
- Fresh Air
- Auto Defrosting
- Easy-cleaning Panel
- Follow Me
- Anti-cold Air Function
- Built-in Drain Pump
- LED Display
- Built-in Filter
- Independent Dehumidification
- Timer
- Auto Swing
- Wired Controller

Multiple Options

Two different versions of Four-way Cassette can be selected based on ceiling arrangements and user preference: Compact Four-way Cassette, Four-way Cassette.

Multiple Airflow Patterns

Seven airflow patterns with up to four flow directions can be selected to suit the requirements of the installation site or the shape of the room. Sub-ducts may also be connected.

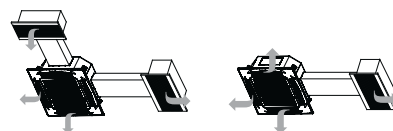
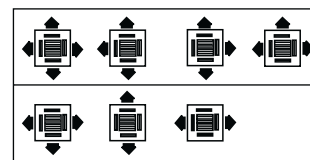

Sub Duct

Connecting a sub-duct enables an indoor unit to be used to also cool a smaller nearby space.



360° Airflow

The Compact Four-way Cassette's 360° air outlets provide strong airflow circulation to cool or heat every corner of a room and evenly control temperature.



High-lift Drain Pump

A drain pump with a 500mm pump head is fitted as standard to the Compact Four-way Cassette. Higher pump heads (of up to 600mm) are available as a customization option. On the Four-way Cassette a drain pump with a 750mm pump head is fitted as standard, simplifying installation of the drain piping.

Four-way Cassette



Compact Four-way Cassette

Model			40VX006H11200010	40VX009H11200010	40VX012H11200010	40VX018H11200010
Power supply			1-phase,220-240V,50Hz			
Capacity	Cooling	kW	2.2	2.8	3.6	
	Heating	kW	2.4	3.2	4.0	5.0
Power input	Cooling	W	50	50	56	
	Heating	W	50	50	56	56
Airflow rate(H/M/L)		m ³ /h	414/313/238	414/313/238	521/409/314	521/409/314
Sound pressure level(H/M/L)		dB(A)	35.8/33.4/23.4	35.8/33.4/23.4	41.5/35.6/28.8	41.5/35.6/28.8
Main body	Net dim.(WxHxD)	mm	570x260x570	570x260x570	570x260x570	570x260x570
	Net/gross weight	kg	16/20	16/20	18/22	18/22
Panel	Net dim.(WxHxD)	mm	647x50x647	647x50x647	647x50x647	647x50x647
	Net/gross weight	kg	2.5/4.5	2.5/4.5	2.5/4.5	2.5/4.5
Piping connections	Liquid/gas pipe	mm	Φ6.35/Φ12.7	Φ6.35/Φ12.7	Φ6.35/Φ12.7	Φ6.35/Φ12.7
	Drain pipe	mm	OD Φ25	OD Φ25	OD Φ25	OD Φ25
Standard controller			Wireless remote controller			
Decoration panel			42VF00A00			

Four-way Cassette

Model			40VK009H11200011	40VK012H11200011	40VK018H11200011	40VK024H11200011	40VK028H11200011
Power supply			1-phase,220-240V,50Hz				
Capacity	Cooling	kW	2.8	3.6	4.5	5.6	7.1
	Heating	kW	3.2	4.0	5.0	6.3	8.0
Power input	Cooling	W	80	80	88	88	88
	Heating	W	80	80	88	88	88
Airflow rate(H/M/L)		m ³ /h	764/638//554	764/638//554	905/740//651	905/740//651	950/767//663
Sound pressure level(H/M/L)		dB(A)	32/31/30	32/31/30	36/34/33	36/34/33	38/36/35
Main body	Net dim.(WxHxD)	mm	840x230x840	840x230x840	840x230x840	840x230x840	840x230x840
	Net/gross weight	kg	21.5/26.7	21.5/26.7	23.7/28.9	23.7/28.9	23.7/28.9
Panel	Net dim.(WxHxD)	mm	950x54.5x950	950x54.5x950	950x54.5x950	950x54.5x950	950x54.5x950
	Net/gross weight	kg	6/9	6/9	6/9	6/9	6/9
Piping connections	Liquid/gas pipe	mm	Φ6.35/Φ12.7	Φ6.35/Φ12.7	Φ6.35/Φ12.7	Φ9.53/Φ15.9	Φ9.53/Φ15.9
	Drain pipe	mm	OD Φ32	OD Φ32	OD Φ32	OD Φ32	OD Φ32
Standard controller			Wireless remote controller				
Decoration panel			40GF00A00				

Model			40VK032H11200011	40VK036H11200011	40VK040H11200011	40VK048H11200011	40VK056H11200011
Power supply			1-phase,220-240V,50Hz				
Capacity	Cooling	kW	8.0	9.0	10.0	11.2	14.0
	Heating	kW	9.0	10.0	11.1	12.5	15.0
Power input	Cooling	W	110	140	165	165	176
	Heating	W	110	140	165	165	176
Airflow rate(H/M/L)		m ³ /h	1200/1021/789	1332/1129/908	1651/1304/1127	1651/1304/1127	1658/1335/1130
Sound pressure level(H/M/L)		dB(A)	42/39/37	43/39/38	45/42/40	45/42/40	46/41/39
Main body	Net dim.(WxHxD)	mm	840x230x840	840x300x840	840x300x840	840x300x840	840x300x840
	Net/gross weight	kg	23.7/28.9	28.7/34.1	28.7/34.1	28.7/34.1	30.9/36.3
Panel	Net dim.(WxHxD)	mm	950x54.5x950	950x54.5x950	950x54.5x950	950x54.5x950	950x54.5x950
	Net/gross weight	kg	6/9	6/9	6/9	6/9	6/9
Piping connections	Liquid/gas pipe	mm	Φ9.53/Φ15.9	Φ9.53/Φ15.9	Φ9.53/Φ15.9	Φ9.53/Φ15.9	Φ9.53/Φ15.9
	Drain pipe	mm	OD Φ32	OD Φ32	OD Φ32	OD Φ32	OD Φ32
Standard controller			Wireless remote controller				
Decoration panel			426F00A00				

Notes:

1. Nominal capacities are based on the following conditions:

- Cooling: indoor temperature 27°C (80.6°F) DB, 19°C WB; outdoor temperature 35°C DB; equivalent refrigerant piping length 7.5m with zero level difference.
- Heating: indoor temperature 20°C DB; outdoor temperature 7°C DB, 6°C WB; equivalent refrigerant piping length 7.5m with zero level difference.

2. Sound pressure level is measured 1.4m below the unit in a semi-anechoic chamber.





Indoor Units

Ducted

Low/Medium Static Pressure Duct (1.5-7.1kW) Medium Static Pressure Duct (A5; 8-14kW)



- Auto Restart Function
- Auto Addressing
- Fresh Air
- Auto Defrosting
- Built-in Filter
- Follow Me
- Anti-cold Air Function
- Built-in Drain Pump
- Timer
- Independent Dehumidification
- Wired Controller
- Super High Air Flow

Compact Design

- Capacities 2,2 to 7,1 kW are just 210mm high
- Capacities 8,0 to 11,2 are 270mm high
- Capacity 14,0 kW is 300mm high

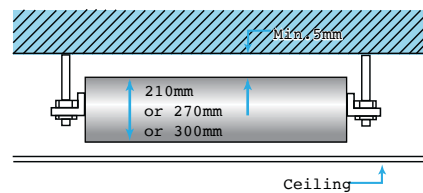

High-lift Drain Pump

A drain pump with a 750mm pump head is fitted as standard, simplifying installation of the drain piping.

Easy Maintenance Access, Flexible Control

As a customization option, for ease of access the electric control box can be separated from the unit by up to 1m. Functional ports including remote on/off dry contact and 220V alarm signal output are included as standard, providing control flexibility.

Flexibility

To provide the flexibility to adapt to differing installation situations, the air inlet may be positioned either on the underside or the rear of the unit.

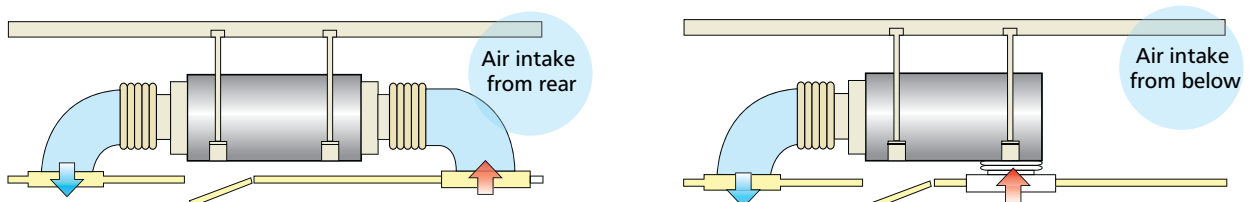

Specifications



Model			42VD006H112013011	42VD009H112013011	42VD012H112013011	42VD018H112013011	42VD024H112013011
Power supply			1-phase,220-240V,50Hz				
Capacity	Cooling	kW	2.2	2.8	3.6	4.5	5.6
	Heating	kW	2.6	3.2	4.0	5.0	6.3
Power input	Cooling	W	68	68	72	80	80
	Heating	W	65	65	69	80	80
Airflow rate(H/M/L)		m ³ /h	538/456/375	538/456/375	597/514/429	811/684/575	811/684/575
External static pressure(Min/Std/Max)		Pa	10(10/30)	10(10/30)	10(10/30)	10(10/30)	10(10/30)
Sound pressure level(H/M/L)		dB(A)	36/35/32	37/35/32	38.6/37.5/33.8	39/37.9/34	39/37.9/34
Net dimension(WxHxD)		mm	740x210x500	740x210x500	740x210x500	960x210x500	960x210x500
Net/gross weight		kg	17.5/20	17.5/20	17.5/20	22.5/26	22.5/26
Piping connections	Liquid/gas pipe	mm	Φ6.35/Φ12.7	Φ6.35/Φ12.7	Φ6.35/Φ12.7	Φ6.35/Φ12.7	Φ9.53/Φ15.9
	Drain pipe	mm	OD Φ25	OD Φ25	OD Φ25	OD Φ25	OD Φ25
Standard controller			Wireless remote controller				

Model			42VD028H112013011	42VD032H112003010	42VD036H112003010	42VD048H112003010	42VD054H112003010
Power supply			1-phase,220-240V,50Hz				
Capacity	Cooling	kW	7.1	8.0	9.0	11.2	14.0
	Heating	kW	8.0	9.0	10.0	12.5	15.5
Power input	Cooling	W	105	231	231	327	355
	Heating	W	105	231	231	327	355
Airflow rate(H/M/L)		m ³ /h	1029/934/781	1350/1166/1031	1350/1166/1031	1800/1565/1389	1900/1643/1400
External static pressure(Min/Std/Max)		Pa	10(10/30)	20(10/50)	20(10/50)	40(10/80)	40(10/100)
Sound pressure level(H/M/L)		dB(A)	41.4/39/35	45.4/39.8/37	45.4/39.8/37	48.0/41.9/38	47.7/43.2/39.0
Net dimension(WxHxD)		mm	1180x210x500	1140x270x710	1140x270x710	1140x270x710	1200x300x800
Net/gross weight		kg	28/31.5	38/46.5	40/48	40/48	49/58
Piping connections	Liquid/gas pipe	mm	Φ9.53/Φ15.9	Φ9.53/Φ15.9	Φ9.53/Φ15.9	Φ9.53/Φ15.9	Φ9.53/Φ15.9
	Drain pipe	mm	OD Φ25	OD Φ25	OD Φ25	OD Φ25	OD Φ25
Standard controller			Wireless remote controller				

Notes:

- Nominal capacities are based on the following conditions:
 - Cooling: indoor temperature 27°C DB, 19°C WB; outdoor temperature 35°C DB; equivalent refrigerant piping length 7.5m (24.6ft.) with zero level difference.
 - Heating: indoor temperature 20°C DB; outdoor temperature 7°C DB, 6°C WB; equivalent refrigerant piping length 7.5m (24.6ft.) with zero level difference.
- Sound pressure level is measured 1.4m below the unit in a semi-anechoic chamber.
- External static pressure is based on high speed indoor airflow.

High Static Pressure Duct



- 
Auto Restart
Function
- 
Auto
Addressing
- 
Independent
Dehumidification
- 
Auto
Defrosting
- 
Built-in
Filter
- 
Follow
Me
- 
Anti-cold Air
Function
- 
Wired
Controller
- 
Timer
- 
Built-in Drain
Pump

Flexible Duct Design

The High Static Pressure Duct indoor unit offers external static pressures of up to 196Pa (capacities 7,1 to 16,0 kW) or 280Pa (capacities 20,0 to 56,0 kW), allowing air supply duct lengths of up to 14m at a height of 6.5m. With a height of just 420mm (capacities 7,1 to 16,0 kW), only 450mm of ceiling space is required.

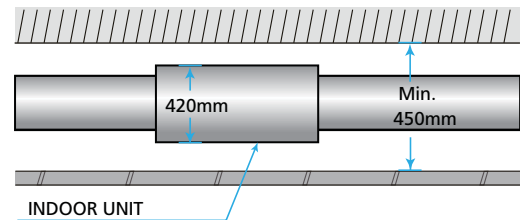
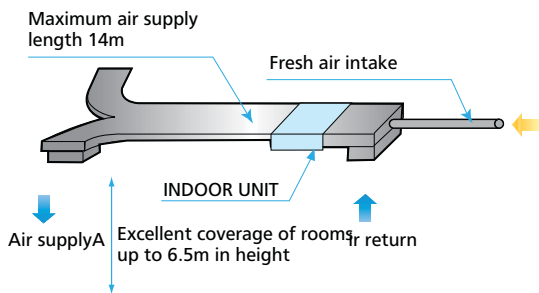

Double-skin Drainage Pan

A double-skin drainage pan provides double protection for ceilings (capacities 7,1 to 16,0 kW and capacities 40,0 to 56,0 kW).

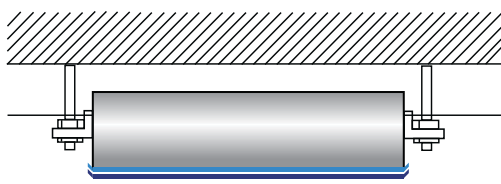

Drain Pump

A drain pump with a 750mm pump head is available as a customization option (capacities 7,1 to 16,0 kW).

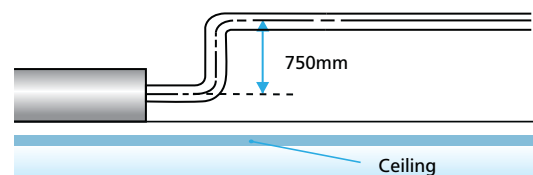

Easy Installation

Flanges for air inlet/outlet ducts are fitted as standard on the High Static Pressure Duct. On capacities 7,0 to 16,0 kW, the expansion valve is fitted inside the unit, requiring no extra connection.

Easy Maintenance Access, Flexible Control

The wireless remote controller is provided as standard and the wired remote controller is available as a customization option. Functional ports including remote on/off dry contact are included as standard, providing additional control flexibility. For ease of installation, the electric control box's display board is factory-fitted and the filter can be accessed either from the rear or from below.

Model			42VD028H112011010	42VD032H112011010	42VD036H112011010	42VD048H112011010	42VD054H112011010	42VD055H112011010
Power supply			1-phase,220-240V,50Hz					
Capacity	Cooling	kW	7.1	8.0	9.0	11.2	14.0	16.0
	Heating	kW	8.0	9.0	10.0	12.5	16.0	17.0
Power input	Cooling	W	240	240	398	512	648	873
	Heating	W	240	240	398	512	648	873
Airflow rate(H/M/L)	m ³ /h		1510/1399/1236	1500/1396/1221	1936/1721/1511	2117/1950/1644	2988/2670/2229	3890/3200/2700
External static pressure(Min/Std/Max)	Pa		40(30/196)	40(30/196)	40(30/196)	50(30/196)	50(30/196)	50(30/196)
Sound pressure level(H/M/L)	dB(A)		48/46/44	48/46/44.5	52/49/47	52/49/47	53/50/48	54/52/50
Net dimension(WxHxD)	mm		952x420x690	952x420x690	952x420x690	952x420x690	1200x400x600	1200x400x600
Net/gross weight	kg		45/50	45/50	46.5/52.4	50.6/56	68/70	70/77.5
Piping connections	Liquid/gas pipe	mm	Φ9.53/Φ15.9	Φ9.53/Φ15.9	Φ9.53/Φ15.9	Φ9.53/Φ15.9	Φ9.53/Φ15.9	Φ9.53/Φ15.9
	Drain pipe	mm	OD Φ32	OD Φ32	OD Φ32	OD Φ32	OD Φ32	OD Φ32
Standard controller	Wireless Remote Controller							

Model			42VD056H112011010	42VD058H112011010	42VD060H112011010	42VD140H112011010	42VD160H112011010	42VD190H112011010
Power supply			1-phase,220-240V,50Hz					
Capacity	Cooling	kW	20.0	25.0	28.0	40.0	45.0	56.0
	Heating	kW	22.5	26.0	31.5	45.0	50.0	63.0
Power input	Cooling	W	1800	1800	1800	2700	2700	3400
	Heating	W	1800	1800	1800	2700	2700	3400
Airflow rate(H/M/L)	m ³ /h		4268/3780/3200	4280/3820/3200	4400/3708/3200	7472/6072/4995	7472/6072/4995	9550/7950/6600
External static pressure(Min/Std/Max)	Pa		140(50/250)	140(50/250)	160(50/250)	50/200/280	50/200/280	50/200/280
Sound pressure level(H/M/L)	dB(A)		59/55/52	59/55/52	59/55/52	61/59/56	61/59/56	63/60/57
Net dimension(WxHxD)	mm		1425x500x928	1425x500x928	1440x505x928	1970x668x902.5	1970x668x902.5	1970x668x902.5
Net/gross weight	kg		115/129	115/129	115/129	232/245	232/245	235/250
Piping connections	Liquid/gas pipe	mm	Φ9.53x2/Φ15.9x2	Φ9.53x2/Φ15.9x2	Φ9.53x2/Φ15.9x2	Φ9.53x2/Φ22.2x2	Φ9.53x2/Φ22.2x2	Φ9.53x2/Φ22.2x2
	Drain pipe	mm	OD Φ32	OD Φ32	OD Φ32	OD Φ32	OD Φ32	OD Φ32
Standard controller	Wireless Remote Controller							

Notes:

- Nominal capacities are based on the following conditions:
 - Cooling: indoor temperature 27°C DB, 19°C WB; outdoor temperature 35°C DB; equivalent refrigerant piping length 7.5m with zero level difference.
 - Heating: indoor temperature 20°C DB; outdoor temperature 7°C DB, 6°C WB; equivalent refrigerant piping length 7.5m with zero level difference.
- Sound pressure level is measured 1.4m below the unit in a semi-anechoic chamber.
- External static pressure is based on high speed indoor airflow.

Fresh Air Processing Unit



- Auto Restart Function
- Auto Addressing
- Follow Me
- Anti-cold Air Function
- Wired Controller

100% Fresh Air Processing Unit

Both fresh air filtration and heating/cooling can be achieved in a single system. Indoor units and the Fresh Air Processing Unit can be connected to the same refrigerant system, increasing design flexibility and greatly reducing total system costs.

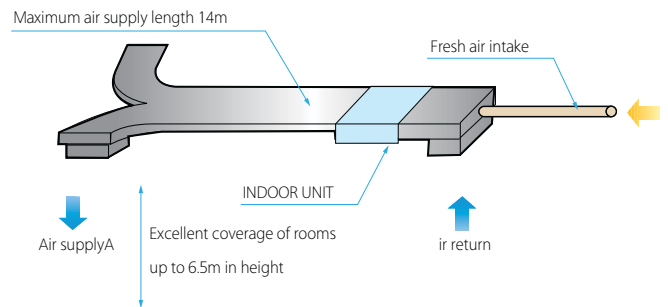

Flexible Duct Design

The Fresh Air Processing unit offers external static pressures of up to 196Pa (capacities 12,5 to 14,0 kW) or 280Pa (capacities 20,0 to 28,0 kW), allowing air supply duct lengths of up to 14m at a height of 6.5m.

The Comfort of Fresh Air

Enjoy the comfort and health benefits of fresh air being drawn into your working or living environment.

Specifications



Model			42VD052H112211010	42VD054H112211010	42VD056H112211010	42VD058H112211010	42VD060H112211010
Power supply			1-phase,220-240V,50Hz				
Capacity	Cooling	kW	12.5	14.0	20.0	25.0	28.0
	Heating	kW	10.5	12.0	18.0	20.0	22.0
Power input	Cooling	W	430	430	1000x2	1063x2	1063x2
	Heating	W	430	430	1000x2	1063x2	1063x2
Airflow rate(H/M/L)		m ³ /h	1700/1350/1050	1700/1350/1050	3150/2650/2300	3300x2850x2500	3300x2850x2500
External static pressure(Min/Std/Max)		Pa	30-220	30-220	50-260	50~260	50~260
Sound pressure level(H/M/L)		dB(A)	54/52/50	54/52/50	54/53/51	55/54/52	55/54/52
Net dimension(WxHxD)		mm	1368x420x691	1368x420x691	1443x470x810	1443x470x810	1443x470x810
Net/gross weight		kg	69.5/76	69.5/76	115/125	115/125	115/125
Piping connections	Liquid/gas pipe	mm	Φ9.53/Φ15.9	Φ9.53/Φ15.9	Φ9.53/Φ15.9	Φ9.53/Φ15.9	Φ9.53/Φ15.9
	Drain pipe	mm	OD Φ25	OD Φ25	OD Φ32	OD Φ32	OD Φ32
Operation temperature range		°C	Heating: -5~16; Fan only: 16~20; Cooling: 20~43				
Standard controller			Wireless Remote Controller				

Notes:

- Nominal capacities are based on the following conditions:
 - Cooling: outdoor temperature 33°C DB, 24°C WB; equivalent refrigerant piping length 7.5m (24.6ft.) with zero level difference.
 - Heating: outdoor temperature 0°C DB, -1°C WB; equivalent refrigerant piping length 7.5m (24.6ft.) with zero level difference.
- Sound pressure level is measured 1.4m below the unit in a semi-anechoic chamber.
- External static pressure is based on high speed indoor airflow.
- The Fresh Air Processing Unit can be used either independently or in conjunction with other types of indoor unit. If used independently, the total capacity of the Fresh Air Processing Units must be between 50% and 100% of that of the outdoor units. If used in conjunction with other types of indoor unit, the total capacity of the Fresh Air Processing Units must not exceed 30% of that of the outdoor units.



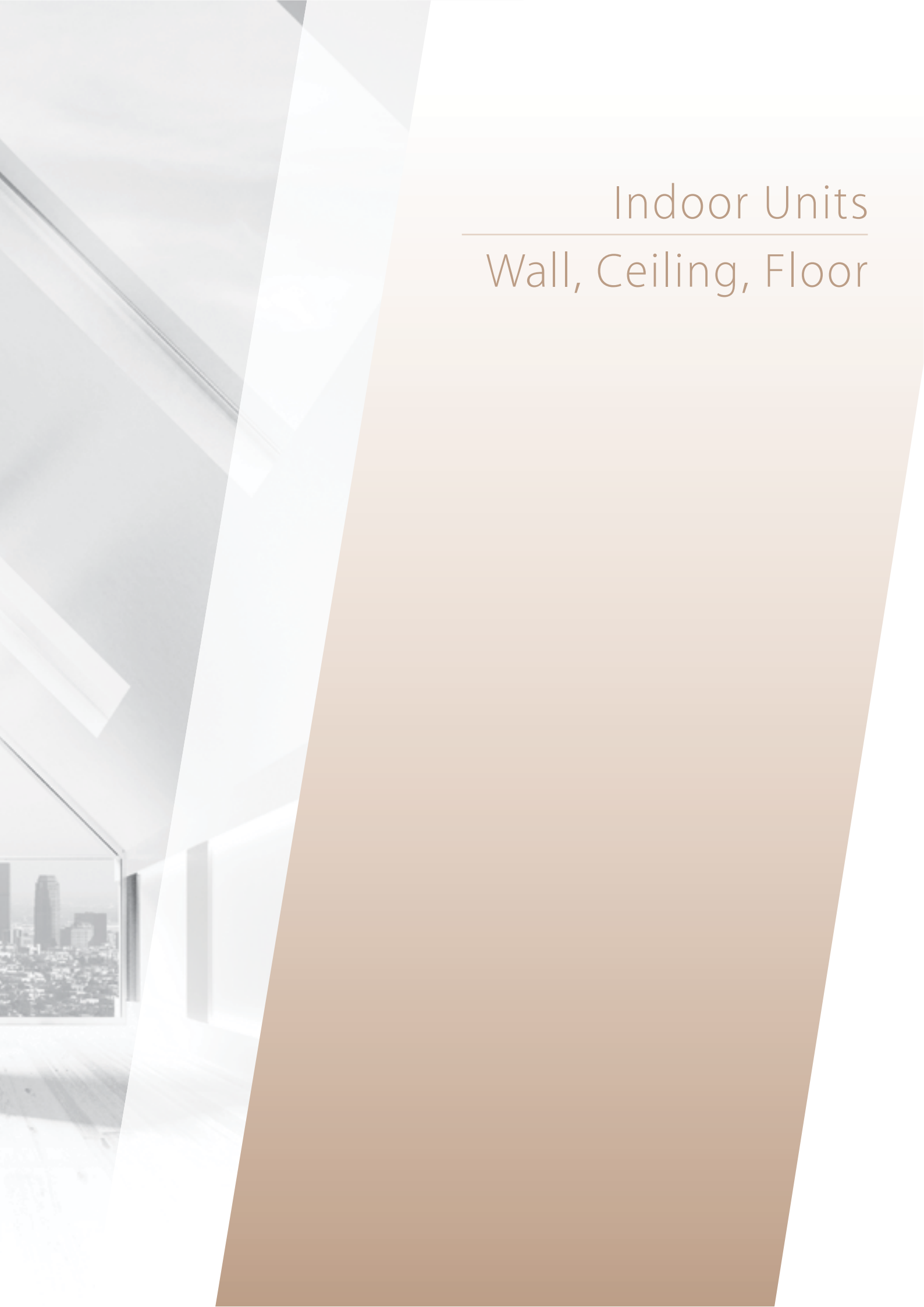

Indoor Units

Wall, Ceiling, Floor

Wall-mounted



- Auto Restart Function
- Auto Addressing
- Easy-cleaning Panel
- Follow Me
- LED Display

Panel with LED display

The front panel and display panel have different colors to choose: white and brown for big panel, blue and brown for small panel.

Convenient installation

Multi-refrigerant outlet pipe method: left\right\rear, more flexible for installation.

For S and R panel, the EXV is built-in the indoor unit, compact size, longer the connection pipe; gas pipe: 468mm; liquid pipe: 550mm, more flexible for installation.

Adopts new type fixing plate, is easy to install and stable.

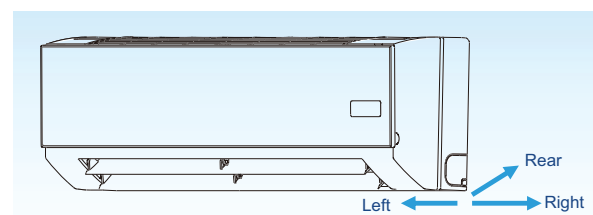

Auto swing louver

The Auto Swing Louver function ensures that the air direction corresponds to the mode selected.

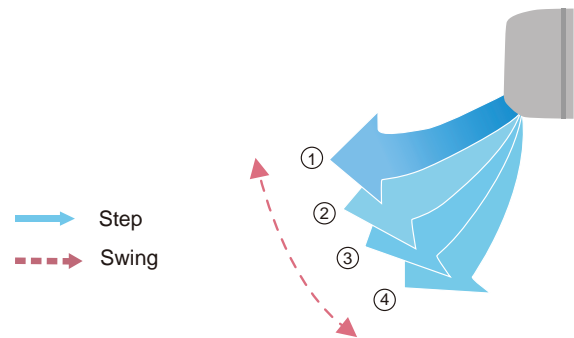

Easy maintenance

The front panel can be removed for easy maintenance access.

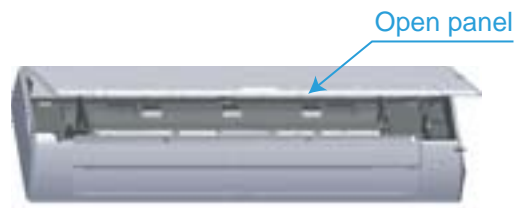

Optimal comfort through better flow control and quiet operations

The mechanical expansion valve offers 2,000-stage element positions to ensure precise flow control and less modulation noise when the EXV is operating for a quiet and comfortable environment. Three air flow speeds: low, medium and high; double air guides. Smoother airflow and less turbulence is ensured by the multi-blade fan and the air guide design.



Specifications

S type panel

Model			42VH006H112000101	42VH009H112000101	42VH012H112000101	42VH018H112000101	42VH024H112000101
Power supply	V- Ph-Hz		220-240~1~50				
Cooling	Capacity	kW	2,2	2,8	3,6	4,5	5,6
	Input	W	28	28	31	44	44
	Rated current	A	0,14	0,14	0,14	0,2	0,2
Heating	Capacity	kW	2,6	3,2	4,0	5,0	6,0
	Input	W	28	28	31	44	44
	Rated current	A	0,14	0,14	0,14	0,2	0,2
Indoor air flow (H/M/L)	m³/h		525/480/430	525/480/430	525/480/430	860/755/630	925/860/755
Indoor noise level (sound pressure)	dB(A)		35/32/29	35/32/29	35/32/29	40/38/34	40/38/34
Indoor unit	Dimension (W*H*D)	mm	915 *290*230	915 *290*230	915 *290*210	1072 *315*230	1072 *315*230
	Net/Gross weight	kg	13/16.5	13/16.5	13/16.5	15.1/18.8	15.1/18.8
Refrigerant type			R410A				
Throttle			Inside Electric expansive valve				
Refrigerant piping	Liquid side/ Gas side	mm	6.35/12.7	6.35/12.7	6.35/12.7	6.35/12.7	9.53/15.9
Drainage water pipe dia.		mm	OD 16.5	OD 16.5	OD 16.5	OD 16.5	OD 16.5
Controller			Wireless WL-12-CM				

- Notes:
1. Nominal cooling capacities are based on the following conditions: return air temperature: 27°CDB, 19°CWB, and outdoor temperature: 35°CDB, equivalent ref. piping: 8m (horizontal)
 2. Nominal heating capacities are based on the following conditions: return air temperature: 20°CDB, outdoor temperature: 7°CDB, 6°CWB, and equivalent ref. Piping: 8m (horizontal)
 3. Sound level is measured 1m below the air outlet horizontally and vertically.
- *Specifications are subject to change without prior notice for product improvement.

R type panel

Model			42VH028H112000102	42VH032H112000102	42VH036H112000102
Power supply		V- Ph-Hz	220-240V~, 1Ph, 50Hz		
Cooling	Capacity	kW	7,1	8,0	9,0
	Input	W	75	86	86
	Rated current	A	0,33	0,39	0,39
Heating	Capacity	kW	8,0	9,0	10,0
	Input	W	75	86	86
	Rated current	A	0,33	0,39	0,39
Indoor air flow (H/M/L)		m ³ /h	1190/880/680	1320/840/640	1320/840/640
Indoor noise level (H/M/L)		dB(A)	47/43/42	48/43/38	49/43/38
Indoor unit	Dimension (W*H*D)	mm	1250*245*325	1250*245*325	1250*245*325
	Net/Gross weight	kg	19.9/25	19.9/25	19.9/25
Refrigerant type			R410A		
Throttle		Type	Inside Electrical expansive valve		
Refrigerant piping	Liquid side/ Gas side	mm	9.53/ 15.9	9.53/ 15.9	9.53/ 15.9
Drainage water pipe diameter			OD 16.5	OD 16.5	OD 16.5
Controller			Wireless WL-12-CM		











Notes:

- Nominal cooling capacities are based on the following conditions: return air temperature: 27°CDB, 19°CWB, and outdoor temperature: 35°CDB, equivalent ref. piping: 8m (horizontal)
- Nominal heating capacities are based on the following conditions: return air temperature: 20°CDB, outdoor temperature: 7°CDB, 6°CWB, and equivalent ref. Piping: 8m (horizontal)
- Sound level is measured 1m below the air outlet horizontally and vertically.

*Specifications are subject to change without prior notice for product improvement.

M9



- 
Auto Restart
Function
- 
Auto
Addressing
- 
Timer
- 
Auto
Defrosting
- 
Easy-cleaning
Panel
- 
Follow
Me
- 
Anti-cold Air
Function
- 
Auto
Swing
- 
LED
Display
- 
Built-in
Filter
- 
Independent
Dehumidification
- 
Wired
Controller

New M Series

Three different series of Wall-mounted indoor units can be selected based on room decor requirements and user preference: M Series, S Series. The elegant new M Series units enhance the aesthetics of any room and are suitable for a wide variety of installation space situations.

High Efficiency, Low Sound Level

Advanced brushless DC fan motors in M Series units operate highly efficiently without generating excessive noise, saving energy at the same time as providing a low-noise work or living space.

Auto Swing Louver

Multiple louver positions and the auto swing ensure precise and flexible airflow control.

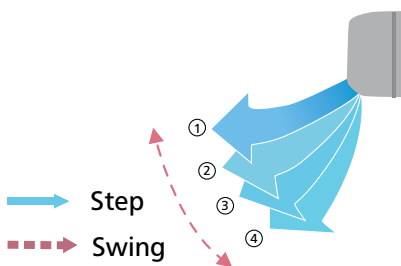

Flexibility

To increase installation flexibility, the expansion valve is fitted internally, increasing compactness, and the refrigerant outlet direction can be left, right or rear as the installation situation requires. A new fixing plate design speeds installation and provides extra stability.

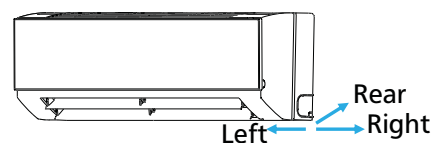

Optimal Comfort Through Better Flow Control

A 2000-stage element mechanical expansion valve ensures precise flow control whilst generating little modulation noise. A multi-blade fan coupled with a dual-blade air guide smooth output airflow and three fan speeds provide flexibility to respond to users' particular comfort requirements.



M Series

Model			42VH006H115000102	42VH009H115000102	42VH012H115000102	42VH018H115000102
Power supply			1-phase,220-240V,50/60Hz			
Capacity	Cooling	kW	2.2	2.8	3.6	4.5
	Heating	kW	2.4	3.2	4	5
Power input	Cooling	W	8	9	19	19
	Heating	W	8	9	19	19
Airflow rate (H/M/L)		m ³ /h	422/393/356	417/370/316	656/573/488	594/507/424
Sound pressure level (H/M/L)		dB(A)	31/30/29	31/30/29	33/32/30	35/33/31
Net dimension (WxHxD)		mm	835x280x203	835x280x203	990x315x223	990x315x223
Net/ Gross weight		kg	8.4/12.1	9.5/13.1	11.4/15.5	12.8/16.9
Piping connections	Liquid/gas pipe	mm	Φ6.35/Φ12.7			
	Drain pipe	mm	OD Φ16.5			
Standard controller			Wireless remote controller			

Model			42VH024H115000102	42VH028H115000102	42VH032H115000102	42VH036H115000102
Power supply			1-phase,220-240V,50/60Hz			
Capacity	Cooling	kW	5.6	7.1	8	9
	Heating	kW	6.3	8	9	10
Power input	Cooling	W	27	49	53	82
	Heating	W	27	49	53	82
Airflow rate (H/M/L)		m ³ /h	747/648/547	1195/1005/809	1195/1005/809	1421/1067/867
Sound pressure level (H/M/L)		dB(A)	38/36/34	44/39/36	44/39/36	48/43/38
Dimension (WxHxD)		mm	990x315x223	1194x343x262	1194x343x262	1194x343x262
Net/ Gross weight		kg	12.8/16.9	17/22.4	17/22.4	17/22.4
Piping connections	Liquid/gas pipe	mm	9.53/ 15.9	9.53/ 15.9	9.53/ 15.9	9.53/ 15.9
	Drain pipe	mm	OD 16.5			
Standard controller			Wireless remote controller			

Ceiling & Floor



- Auto Restart Function
- Auto Addressing
- Timer
- Auto Defrosting
- Easy-cleaning Panel
- Follow Me
- Anti-cold Air Function
- Auto Swing
- LED Display
- Built-in Filter
- Independent Dehumidification
- Wired Controller

Flexibility

A sleek design suits installation either on the ceiling or floor, providing flexibility to accommodate a wide range of room designs.

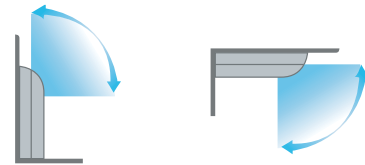
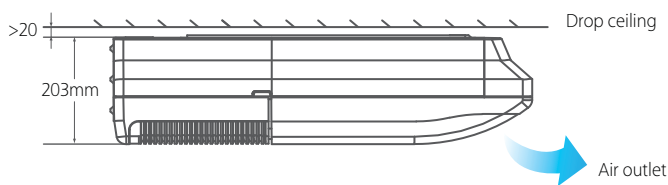

The unit can be installed either horizontally on the ceiling or vertically against the wall.

Wide-Angle Swing

A wide-angle swing together with bi-directional louver swing allows the positioning of the unit to be selected to suit the room's decor, whilst ensuring that full-room cooling and heating coverage is achieved.



Wide-angle swing

Increased Comfort

Sound levels as low as 36dB(A) are achieved using electronic expansion valves which ensure precise flow control whilst generating little modulation noise. A multi-blade fan coupled with a dual-louver air guide smooth output airflow.

Specifications



Model			42VF012H112000010	42VF018H112000010	42VF024H112000010	42VF028H112000010	42VF032H112000010
Power supply			1-phase, 220-240V, 50Hz				
Capacity	Cooling	kW	3.6	4.5	5.6	7.1	8.0
	Heating	kW	4.0	5.0	6.3	8.0	9.0
Power input	Cooling	W	34	125	125	125	143
	Heating	W	34	125	125	125	143
Airflow rate(H/M/L)		m ³ /h	650/570/500	800/600/500	800/600/500	800/600/500	1,200/900/700
Sound pressure level(H/M/L)		dB(A)	40/38/36	43/41/38	43/41/38	43/41/38	45/43/40
Net dimension(WxHxD)		mm	990x206x660	990x206x660	990x206x660	990x206x660	1280x206x660
Net/gross weight		kg	28/34	29/35	29/35	29/35	34/41
Piping connections	Liquid/gas pipe	mm	Φ6.35/Φ12.7	Φ6.35/Φ12.7	Φ9.53/Φ15.9	Φ9.53/Φ15.9	Φ9.53/Φ15.9
	Drain pipe	mm	OD Φ16	OD Φ16	OD Φ16	OD Φ16	OD Φ16
Standard controller			Wireless remote controller				

Model			42VF036H112000010	42VF048H112000010	42VF054H112000010	42VF055H112000010
Power supply			1-phase, 220-240V, 50Hz			
Capacity	Cooling	kW	9.0	11.2	14.0	16.0
	Heating	kW	10.0	12.5	15.5	18.0
Power input	Cooling	W	143	182	182	300
	Heating	W	143	182	182	300
Airflow rate(H/M/L)		m ³ /h	1200/900/700	1980/1860/1730	1980/1860/1730	1980/1860/1730
Sound pressure level(H/M/L)		dB(A)	45/43/40	47/45/42	47/45/42	47/45/42
Net dimension(WxHxD)		mm	1280x206x660	1670x244x680	1670x244x680	1670x285x680
Net/gross weight		kg	34/41	49/58	49/58	57.5/63.5
Piping connections	Liquid/gas pipe	mm	Φ9.53/Φ15.9	Φ9.53/Φ15.9	Φ9.53/Φ15.9	Φ9.53/Φ15.9
	Drain pipe	mm	OD Φ16	OD Φ16	OD Φ16	OD Φ25
Standard controller			Wireless remote controller			

Notes:

1. Nominal capacities are based on the following conditions:

- Cooling: indoor temperature 27°C DB, 19°C WB; outdoor temperature 35°C DB; equivalent refrigerant piping length 7.5m with zero level difference.

- Heating: indoor temperature 20°C DB; outdoor temperature 7°C DB, 6°C WB; equivalent refrigerant piping length 7.5m with zero level difference.

2. Floor standing: Sound pressure level is measured at a position 1m in front the unit and 1m above the floor in a semi-anechoic chamber.

Ceiling mounted: Sound pressure level is measured at a position 1m in front and 1m below the unit in a semi-anechoic chamber.

Floor Standing



- Auto Restart Function
- Follow Me
- Anti-cold Air Function
- Auto Addressing
- Auto Defrosting
- Independent Dehumidification
- Timer
- Wired Controller

Flexibility

The Floor Standing indoor unit can be installed on the floor or, for easier floor cleaning, hung on the wall with piping running from the rear. The streamlined appearance complements any room's decor.

Casing Options

At just 212mm deep, the F3B concealed floor standing unit can be installed around the perimeter of a room, hidden behind the skirting board, and special installation methods can be used to eliminate noise from the room space. The F4 (front air intake) and F5 (underside air intake) offer a choice of air intake options.



F3B (concealed)

Concealed

Model			42VS006H112003010	42VS009H112003010	42VS012H112003010	42VS018H112003010	42VS024H112003010	42VS028H112003010	42VS032H112003010
Power supply			1-phase,220-240V,50Hz						
Capacity	Cooling	kW	2.2	2.8	3.6	4.5	5.6	7.1	8.0
	Heating	kW	2.4	3.2	4.0	5.0	6.3	8.0	9.0
Power input	Cooling	W	40	45	49	50	95	139	139
	Heating	W	40	45	49	50	95	139	139
Airflow rate(H/M/L)		m ³ /h	530/456/400	569/485/421	624/522/375	660/542/440	1,150/970/830	1,380/1,100/870	1,380/1,100/870
Sound pressure level(H/M/L)		dB(A)	36/33/29	36/33/29	37/34/30	37/34/30	41/35/31	44/39/33	44/39/33
Net dimension(WxHxD)		mm	840x545x212	840x545x212	1040x545x212	1040x545x212	1336x545x212	1336x545x212	1336x545x212
Packing dimension(WxHxD)		mm	939x639x305	939x639x305	1139x639x305	1139x639x305	1425x639x305	1425x639x305	1425x639x305
Net/gross weight		kg	25/27	25/27	29.5/34	29.5/34	33/39	33/39	36/40
Piping connections	Liquid/gas pipe	mm	Φ6.35/Φ12.7	Φ6.35/Φ12.7	Φ6.35/Φ12.7	Φ6.35/Φ12.7	Φ9.53/Φ15.9	Φ9.53/Φ15.9	Φ9.53/Φ15.9
	Drain pipe	mm	OD Φ16	OD Φ16	OD Φ16	OD Φ16	OD Φ16	OD Φ16	OD Φ16
Standard controller			Wireless remote controller						

Front air inlet

Model			42VS006H112002010	42VS009H112002010	42VS012H112002010	42VS018H112002010	42VS024H112002010	42VS028H112002010	42VS032H112002010
Power supply			1-phase,220-240V,50Hz						
Capacity	Cooling	kW	2.2	2.8	3.6	4.5	5.6	7.1	8.0
	Heating	kW	2.4	3.2	4.0	5.0	6.3	8.0	9.0
Power input	Cooling	W	40	40	49	49	95	139	139
	Heating	W	40	40	49	49	95	139	139
Airflow rate(H/M/L)		m ³ /h	530/456/400	569/485/421	624/522/375	660/542/440	1,150/970/830	1,380/1,100/870	1,380/1,212/1,023
Sound pressure level(H/M/L)		dB(A)	36/33/29	36/33/29	37/34/30	37/34/30	41/35/31	44/39/33	44/39/33
Net dimension(WxHxD)	F4	mm	1000x625x220	1000x625x220	1200x625x220	1200x625x220	1500x625x 220	1500x625x 220	1500x625x 220
Packing dimension(WxHxD)	F4	mm	1089x722x312	1089x722x312	1289x722x312	1289x722x312	1589x722x312	1589x722x312	1589x722x312
Net/gross weight	F4	kg	30/35	30/35	37/43	37/43	44/50	44/50	44/50
Piping connections	Liquid/gas pipe	mm	Φ6.35/Φ12.7	Φ6.35/Φ12.7	Φ6.35/Φ12.7	Φ6.35/Φ12.7	Φ6.35/Φ12.7	Φ9.53/Φ15.9	Φ9.53/Φ15.9
	Drain pipe	mm	OD Φ16	OD Φ16	OD Φ16	OD Φ16	OD Φ16	OD Φ16	OD Φ16
Standard controller			Wireless remote controller						

Notes:

1. Nominal capacities are based on the following conditions:

- Cooling: indoor temperature 27°C DB, 19°C WB; outdoor temperature 35°C DB; equivalent refrigerant piping length 7.5m with zero level difference.

- Heating: indoor temperature 20°C DB; outdoor temperature 7°C DB, 6°C WB; equivalent refrigerant piping length 7.5m with zero level difference.

2. Floor standing: Sound pressure level is measured at a position 1m in front the unit and 1m above the floor in a semi-anechoic chamber.

Ceiling mounted: Sound pressure level is measured at a position 1m in front and 1m below the unit in a semi-anechoic chamber.

Console



- Auto Restart Function
- Auto Addressing
- Timer
- Auto Defrosting
- Easy-cleaning Panel
- Follow Me
- Anti-cold Air Function
- Auto Swing
- LED Display
- Built-in Filter
- Independent Dehumidification
- Wired Controller

Compact and Stylish

The elegant, space-saving design of the Console unit complements any room's decor. The expansion valve is installed inside the indoor unit for added compactness.

High-Efficiency Filter

Formaldehyde nemesis filter is fitted as standard and active-carbon and biological anti-virus filter are available as a customization option.

High Comfort

A wide-angle swing together with auto swing louvers and five fan speed options ensure that airflow reaches every corner of the room. A 2000-stage element mechanical expansion valve ensures precise flow control whilst generating little modulation noise.

Flexibility

The Console unit can be installed on the floor or lower part of the wall. Full capacity is still achieved even when the underside air inlet is unavailable.



Two Air Outlets and Four Air Inlets

The Console unit's combination of four air inlets and two air outlets ensure that cooling and heating is distributed in all directions.

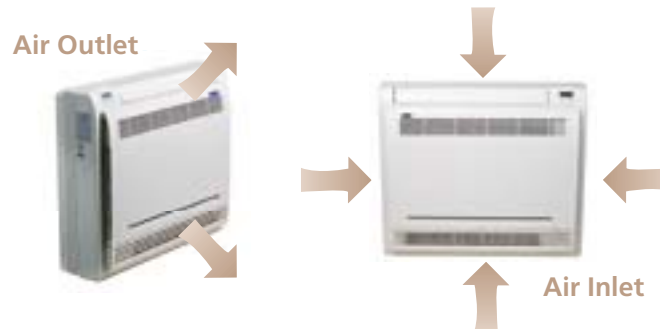

Low-noise Design

A five-speed fan allows airflow customization whilst maintaining low-noise, low power consumption operation.



Sound levels as low as 26dB(A)

Model			42VC006H112000010	42VC009H112000010	42VC012H112000010	42VC018H112000010
Power supply			1-phase,220-240V,50Hz			
Capacity	Cooling	kW	2.2	2.8	3.6	4.5
	Heating	kW	2.6	3.2	4.0	5.0
Power input	Cooling	W	20	24	33	44
	Heating	W	20	24	33	44
Airflow rate(H/M/L)		m ³ /h	430/345/229	510/430/229	510/430/229	660/512/400
Sound pressure level(H/M/L)		dB(A)	38/32/26	39/33/27	39/33/27	42/39/36
Net dimension(WxHxD)		mm	700x600x210	700x600x210	700x600x210	700x600x210
Packing dimension(WxHxD)		mm	810x710x305	810x710x305	810x710x305	810x710x305
Net/gross weight		kg	14/19	15/20	15/20	15/20
Piping connections	Liquid/gas pipe	mm	Φ6.35/Φ12.7	Φ6.35/Φ12.7	Φ6.35/Φ12.7	Φ6.35/Φ12.7
	Drain pipe	mm	OD Φ16	OD Φ16	OD Φ16	OD Φ16
Standard controller			Wireless remote controller			

1. Nominal capacities are based on the following conditions:

- Cooling: indoor temperature 27°C DB, 19°C WB; outdoor temperature 35°C DB; equivalent refrigerant piping length 7.5m with zero level difference.

- Heating: indoor temperature 20°C DB; outdoor temperature 7°C DB, 6°C WB; equivalent refrigerant piping length 7.5m with zero level difference.

2. Sound pressure level is measured at a position 1m in front the unit and 1m above the floor in a semi-anechoic chamber.





Control Systems

Control Systems

Network Control

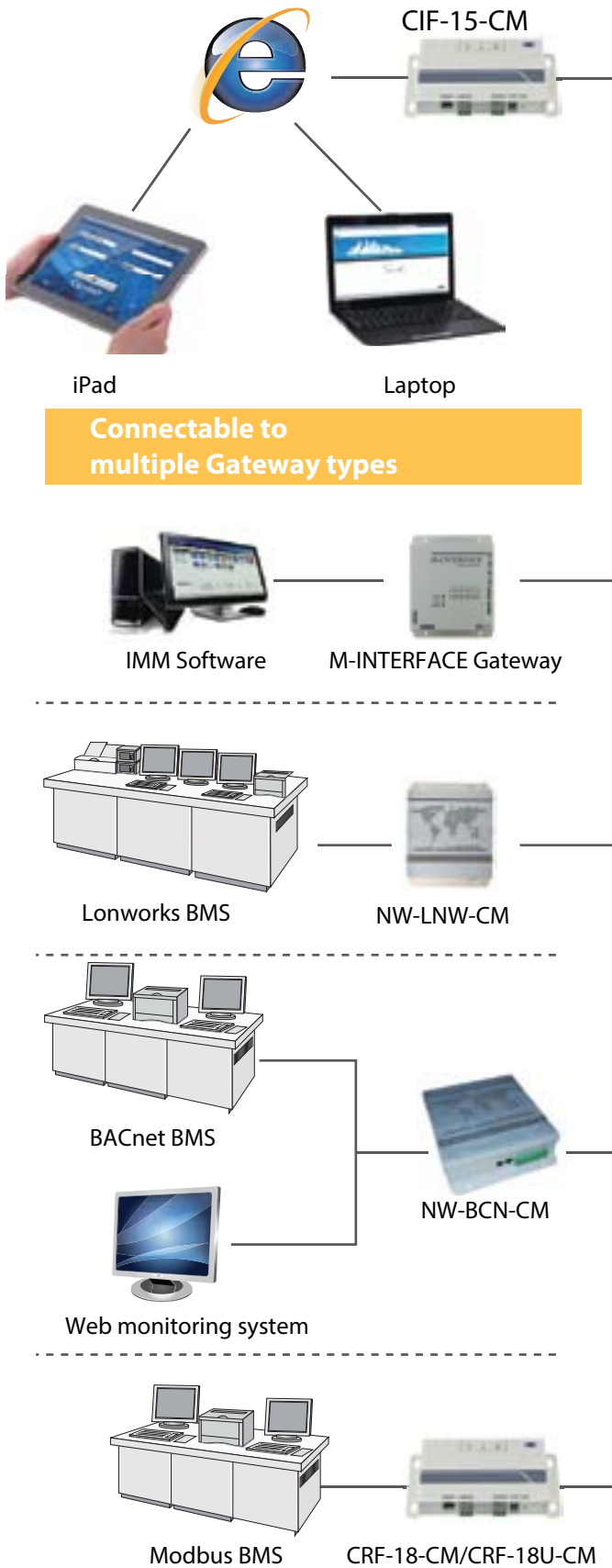

Centralized Control

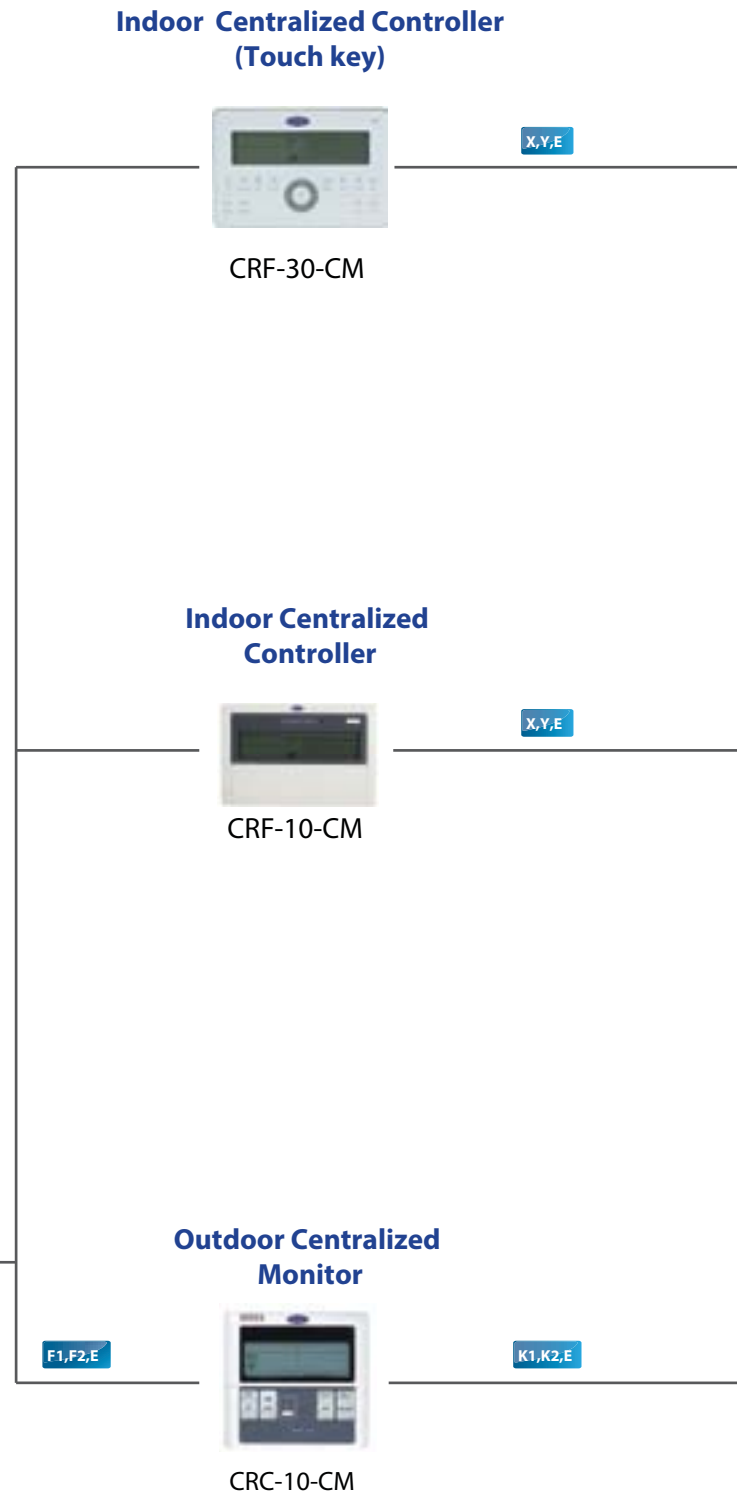

Note: The wires in the diagram show the signal flows only, while not represent the actual connecting ways.

Individual control

Wired controller

WR-12-CM
WR-29B-CM
WR-120B-CM
WR-90D-CM



Remote controller

WL-12-CM
WL-14-CM



Accessories

Card-key Interface CA-NIM05



CA-NIM05



Card-key



Wired controller

Infrared Sensor CA-NIM09



Infrared control box



Infrared sensor module



Wired controller

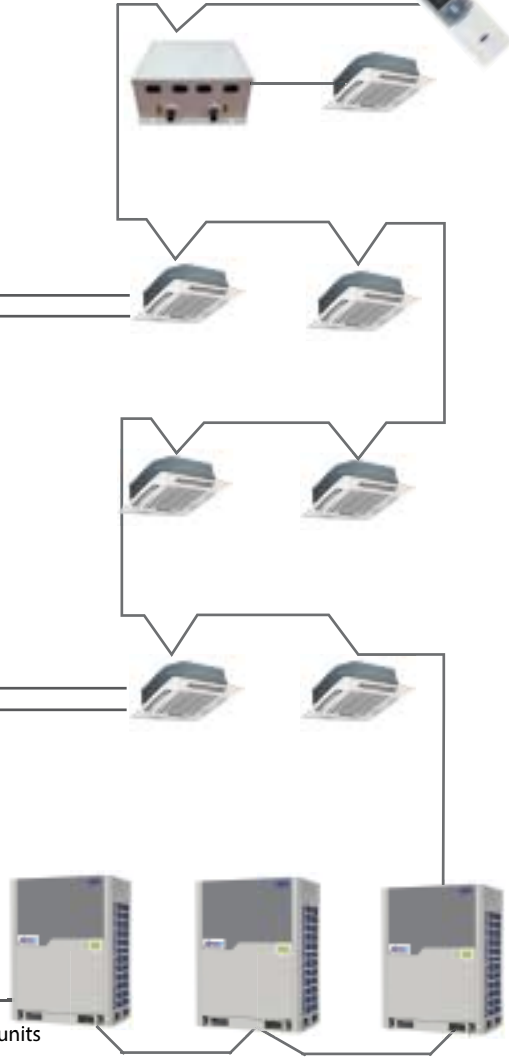

Outdoor units

Wireless Remote Controller



WL-14-CM



WL-12-CM

Model Name	WL-14-CM	WL-12-CM
Mode change	√	√
Temp. setting	√	√
Fan speed control	√	√
Keyboard lock	√	√
Swing function	√	√
Air direction	√	√
24h timer	√	√
Clock display		√
Address setting	√	√
Follow me function	√	
26°C shortcut setting	√	
Background light	√	√
Dimensions (HxWxD)mm	150x60x15	150x65x20

Wireless Remote Controller



WR-90D-CM



**WR-29B-CM
WR-120B-CM**



Auto mode



DRY mode



HEAT mode



COOL mode



FAN mode



Silent mode



Timer



Lock



Filter cleaning reminder



Follow Me



Address setting

Model Name	WR-90D-CM	WR-29B-CM	WR-120B-CM
Fan speed control	√	√	√
Mode change	√	√	√
Auto mode			√*
Keyboard lock	√	√	√
Swing function	√	√	√
Background light	√	√	√
24h timer	√	√	√
Clock display	√	√	√
Address setting	√	√	
Receiving remote signal	√	√	
Clean filter reminder	√	√	√
Follow me function	√	√	
Silent mode	√	√	√
°F/°C initial setting	√	√	√
Auto restart	√	√	√
Error reporting			√
Dimensions (HxWxD)mm	86x86x20	120x120x20	120x120x20

*only available for heat recovery VRF series,

Centralized Controller

Indoor Centralized Controller



CRF-10-CM



CRF-30-CM

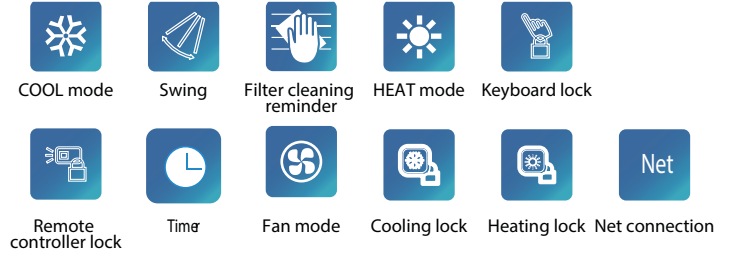

Weekly Schedule Centralized Controller



WCRF-10-CM

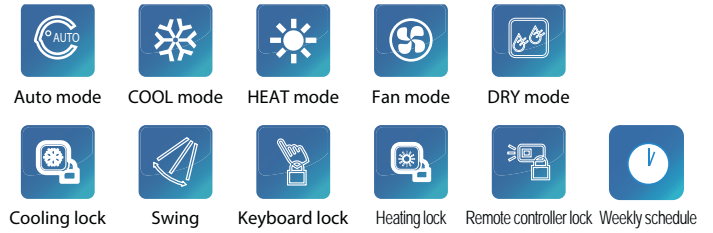

Model	CRF-30-CM	CRF-10-CM	WCRF-10-CM
Max. number of indoor units	64	64	64
Group control	√	√	√
Individual control	√	√	√
Fan speed control	√	√	√
Model selection	√	√	√
Mode lock	√	√	√
Remote controller lock	√	√	√
Keyboard lock	√	√	√
Weekly schedule timer			√
24h timer	√	√	√
Error check	√	√	√
Emergency start	√	√	√
Emergency stop	√	√	√
Background light	√	√	√
Swing function	√	√	√
Air filter cleaning reminder	√		
Parameter query	√	√	√
BMS access	√	√	
Dimensions (HxWxD)mm	180x122x78	179x119x74	179x119x74

Unified On/Off Controller

Feature



CRF-90-CM
Max.16 units

Unified controller design with graceful appearance and explicit panel.

- Centralized Control
- Short press: Only turn ON/OFF the last time operated indoor units
- Long press (3 seconds): Can turn ON/OFF all indoor units.
- Operation Mode Selection Switch (Cooling, Heating)
- Sleep and memory function
- Connect up to 16 indoor units

If no operation to be conducted at the controller after 25 seconds, system would enter to sleep mode, all indicators are faded. Press any key to recovery the displaying.

Outdoor Centralized Monitor

Feature



CRC-10-CM
Max. 8 systems

- RS485 communication
- Up to 8 systems, max.32 outdoor units can be centralized monitored
- It can display the operating parameters of outdoor units
- It can display the error or protection code of outdoor unit
- Dimensions (HxWxD) mm: 120x120x15

- Query parameters
- Protection/ Error codes
- Power consumption
- With the odu communication
- With the PC communication
- Forced Cooling

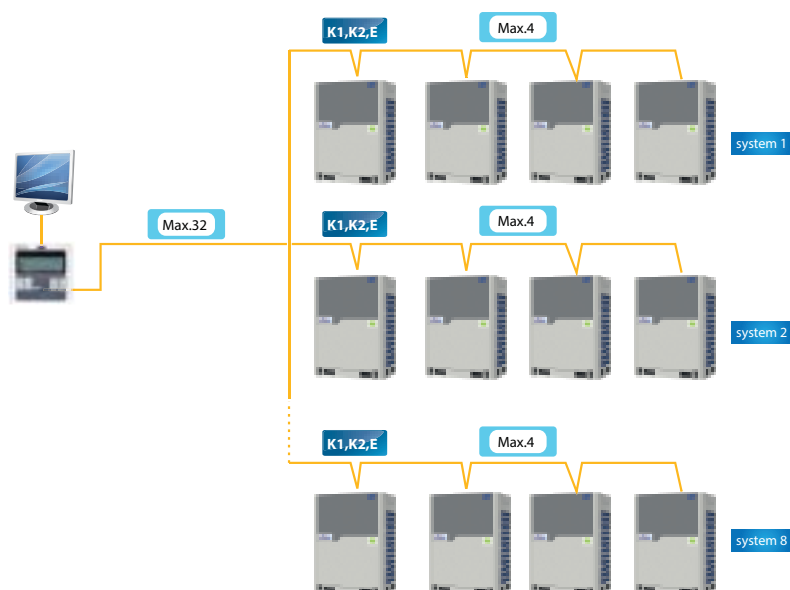

Central Control Software



Intelligent Manager of Carrier

4th Generation Network Control System



4GNS-10-CM 4GNS-10-IF

Functions

Intelligent Manager of Carrier, designed specifically to control VRF systems, is based on a centralized format and dedicated to the complete control and monitoring of all the system's functions. It can be used as a flexible multi-purpose system and applied to a variety of needs, according to the scale, purpose and control method of each building.

- Up to 4 M-interfaces, 64 refrigerant systems, 1,024 indoor units, and 256 outdoor units can be controlled by one PC
- Web Access
- User friendly operation
- Central building monitoring and control
- Energy saving management
- SMS modem (optional)
- Electricity charge distribution
- Annual schedule control
- Low-load operation indicate
- Generate operational history reports (daily, weekly, monthly)
- Fault display & Warning message
- Filter replacement reminder
- Emergency stop and Alarm signal output

Network Control Application

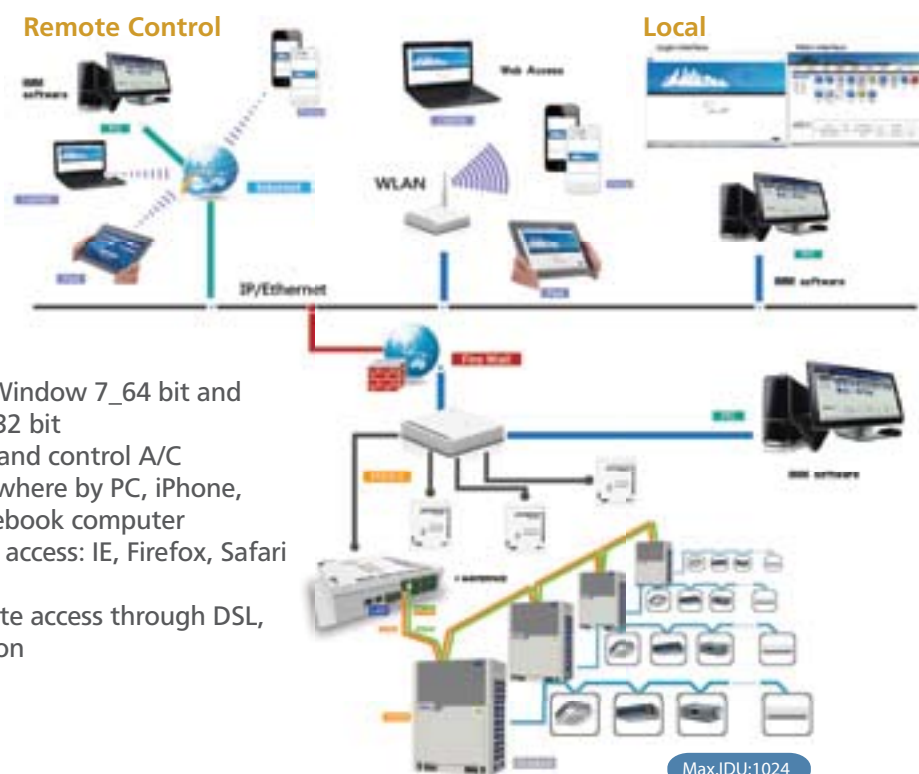

- Can run on ,Window 7_64 bit and Window XP_32 bit
- Can monitor and control A/C anytime, anywhere by PC, iPhone, iPad and notebook computer
- Support WEB access: IE, Firefox, Safari and Chrome
- Enables remote access through DSL, VPNs and so on

Max.IDU:1024

Accessories

Data converter



CIF-15-CM

- Can realize data conversion between TCP/IP protocol and 485 protocol
- WEB function realizes VRF system's webpage access
- User can monitor and query the air conditioners through LAN and WAN
- Providing the TCP / IP port for VRF system of Carrier to achieve WEB/ HTTP/TCP/IP access
- Can remotely control the A/C systems through computer, iPhone, iPad or other intelligent terminals

Network example

- Can be directly connected with XYE port of the indoor units
- Up to connect 64 indoor units
- CRF-10-CM/CRF-30-CM is optional and can be connected with CIF-15-CM through F1, F2 and E ports
- The system consisting A/C system, data converter CIF-15-CM, router, cloud server and control terminal

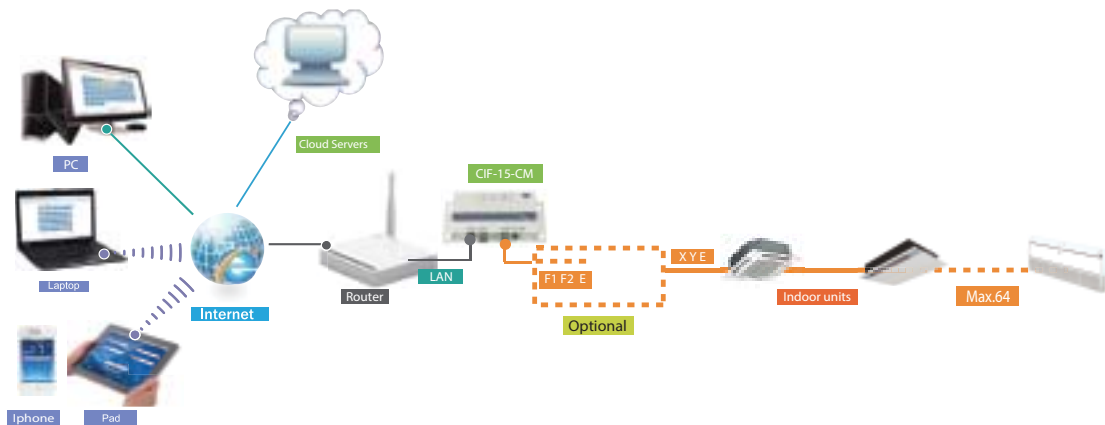

Simply control interface

- Software control/ Cloud server control (WEB access)
- Click & operate, a user-friendly interface
- Allows signal and group control
- Simplified user control interface
- Colour indication and icon makes it easy to recognize unit state
- Full screen display and the temperature can be adjusted by fingers' sliding



BACnet® BMS Gateway

Feature



NW-BCN-CM
BACnet Gateway

- BACNET protocol network
- Web Access Function
- BTL certification
- Dimensions (H*W*D) mm: 319*251*61
- Contains 4 groups of RS485 communication ports
- Connect up to 256 indoor units or 128 outdoor units to the BMS

Modbus BMS Gateway

Feature



CRF-18-CM/CRF-18U-CM
Modbus Gateway

- Directly bridge the IDU to the Modbus network
- One CRF-18-CM can connect max. 64 IDU and 40 outdoor unit
- One CRF-18U-CM can connect max. 16 IDU
- Built-in WEB server function
- Can't connect with central controller
- Dimensions(H*W*D)mm:187*115*25

LonWorks® BMS Gateway

Feature



NW-LNW-CM
LonWorks Gateway

- Directly bridge the IDU to the LonWorks network
- One gateway max. connect 64 IDU
- Can't connect with central controllers
- Only can monitor/control indoor unit
- Dimensions (H*W*D) mm: 319*251*61

Accessories

KNX Gateway



NW-KNX-CM
KNX Gateway

Feature

- External power is not required and direct connect to the KNX EIB bus
- One KNX connect one indoor unit
- Easy installation and directly connects with one indoor unit through the RS485 bus
- Directly connect to the KNX bus
- KNX certification
- Dimensions (H*W*D) mm: 85*51*16

3-Phase Protector



HWUA



DPB71CM48
3-phase protector

Feature

- Detects power status and take protective action to stop the compressor from being damaged
- Automatically distinguishes the abnormal power supply conditions and automatically recovers
- Auto restart after recovery

Digital Power Ammeter



DTS634/DTS636
Digital Power Ammeter

Feature

- Calculates power consumption
- Doesn't need to adjust after long-term use
- Corresponds one outdoor unit to one digital power ammeter
- Dimensions (H*W*D) mm: 230*145*72

Remote Alarm Controller

Feature



WR-32-CM
ODU alarm module

- It can connect up to 16 indoor units through XYE port.
- With a display panel connected to WR-150A-CM, signal from wired controller and remote controller can control a group of indoor units simultaneously and all indoor units will run at the same setting parameters
- Dimensions (H*W*D) mm: 85*150*70

Indoor Unit Group Controller

Feature



WR-150A-CM

- Design for outdoor alarm and monitoring
- It doesn't display the ODU's working parameters, it can connect the alarm device when the ODU is working abnormally, in which case the RUN light will flash
- Access to network monitoring system
- 220V power input
- 220V AC output for the alarm device
- Dimensions (H*W*D) mm: 85*150*70

Outdoor Unit Dry Contact

Feature



WR-150B-CM

- Connect the outdoor unit through K1 K2 E three terminals, offer 3 dry contact in 3 different states through status output
- Dimensions (H*W*D) mm: 85*150*70

Accessories

Hotel Key Card Interface Module

Hotel Key Card Interface Module



CA-NIM05/E



CA-NIM05B/E

Key Features

- Special design for hotel guest room, working with hotel card system
- When the Card Key is in place, the air conditioner is activated
- When the Card Key is removed, the air conditioner switches off, to avoid cooling an unoccupied room and save energy
- Built-in auto restart function
- Compatible with remote and wired controllers
- The CA-NIM05/E works in conjunction with a high voltage relay
- The CA-NIM05B/E can be connected directly to the hotel card slot system (AC 220V) without the need for a high voltage relay
- CA-NIM05/E 15.5*86*72.8 ; CA-NIM05B/E 87*150*70

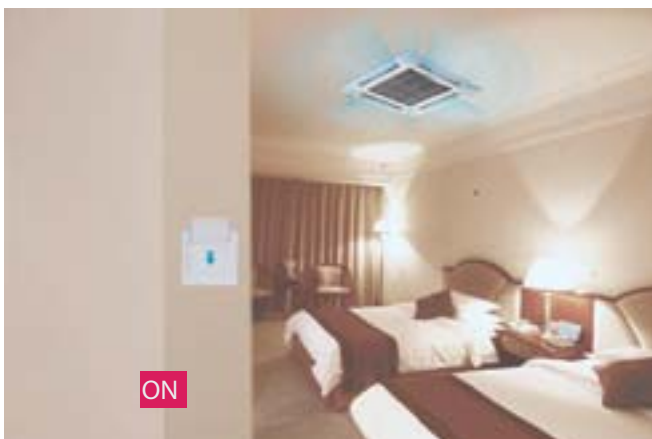

Infrared Sensor Controller



CA-NIM09

Feature

- The infrared sensor is suitable to be used in hotel, offices, conference room, residence, etc
- When someone gets into the room, air conditioner will start automatic. If no one activities, it will be turn off. It controls the AC's on/off by the infrared that our body has delivered
- This function will save energy since it minimizes the unnecessary energy usage by powering off when the area is empty
- Dimensions (H*W*D) mm:
sensor part 46*30*25.6 control box 86*72.8*15.5

AHU Control Box



AHUKZ-01B/AHUKZ-02B/AHUKZ-03B

AHUKZ-01B/AHUKZ-02B/AHUKZ-03B

X-Power Standard functions inside.

Can be used to connect VRF outdoor units with DX AHU or other brand indoor units.

Introduction

AHUKZ-01B/AHUKZ-02B/AHUKZ-03B is an independent control box that can connect a AHU to X-Power system to realize centralized control with X-Power system. Control box wiring is as follows:

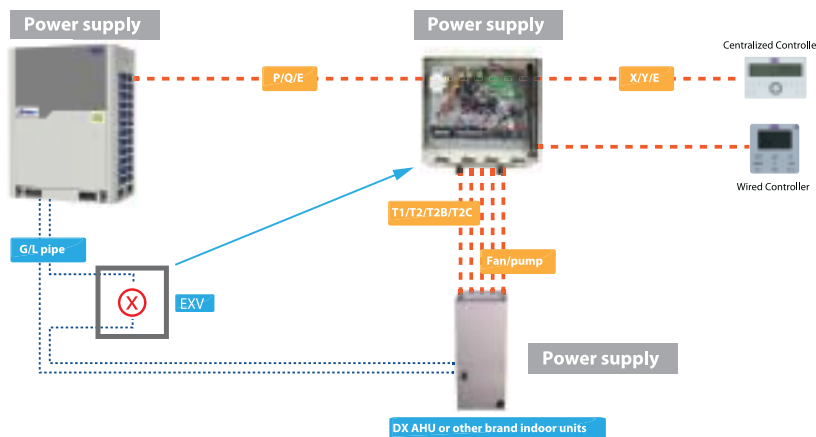

Feature

Maximum 4 AHU Control Box can be parallel installed to one 3rd party indoor unit Interface to allow other brand's DX AHU connecting to our VRF outdoor units.

DX AHU connection kit consist of control part, EXV part, temperature sensors and wired controller.

- Access to network monitoring system
- Dimensions (H*W*D) mm: 335*375*150





Heat Recovery Ventilator

Heat Recovery Ventilator

Alternative fan motor

Versions for AC/DC fan motors.

Enhanced Efficiency

The heat recovery ventilator (HRV) can greatly reduce energy losses and room temperature fluctuations caused by the ventilation process. The HRV's strong performance is a result of the advanced technology incorporated into its design. The heat exchanger core is made of specially treated paper which gives enhanced temperature and humidity control. Temperature exchange efficiency is over 65% and enthalpy exchange efficiency is 50-65%.

Model Names

HRV-200 HRV-500
HRV-300 HRV-800
HRV-400 HRV-1000



HRV-1500
HRV-2000

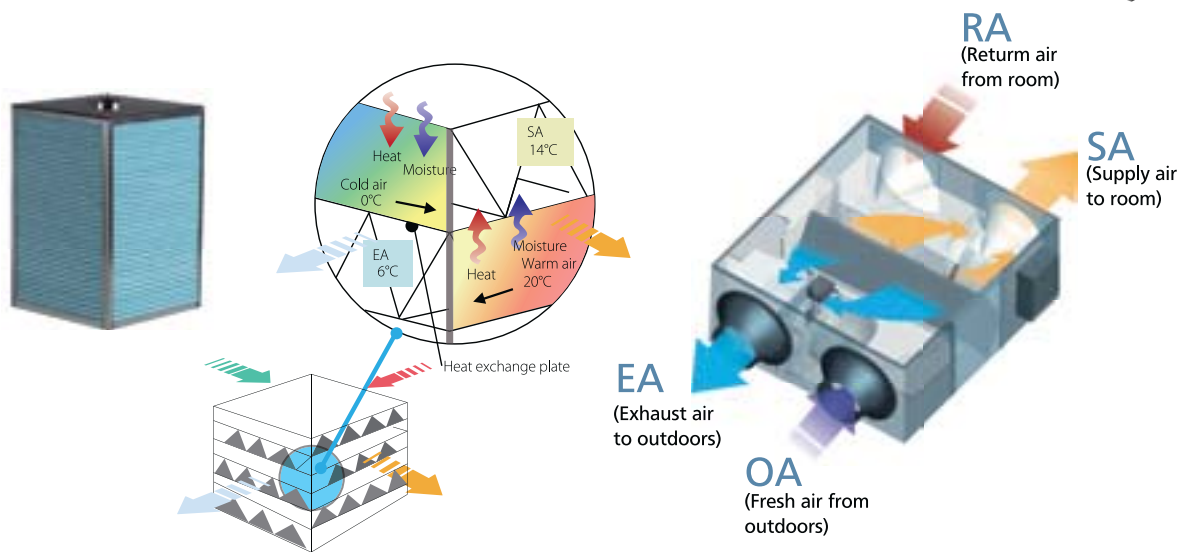

Low noise

Soundproofing is used to guarantee quiet operation.

Flexibility

Heights starting from as little as 264mm and weights from as little as 23kg mean that the HRV can be easily installed even where space is limited.

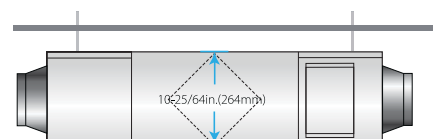

Multiple Modes

Heat exchange mode

The flows of incoming and outgoing air pass close to each other, allowing heat transfer between the two channels. During summer, incoming air is cooled by the indoor air being exhausted and in winter, incoming air is warmed.

Bypass mode

In mild climates or seasons, where temperature and humidity differences between indoors and outdoors are small, the HRV can work as a conventional ventilation fan. In standard bypass mode the supply and exhaust fans run at the same speed.

Air supply mode

Air supply mode is a form of bypass mode where the supply fan is set to run faster than the exhaust fan, which is useful in mild climate installations with high fresh air ventilation requirements.

Exhaust mode

Exhaust mode is a form of bypass mode where the exhaust fan is set to run faster than the supply fan, which is useful in mild climate installations with large amounts of exhaust air to be expelled.

Heat exchange mode

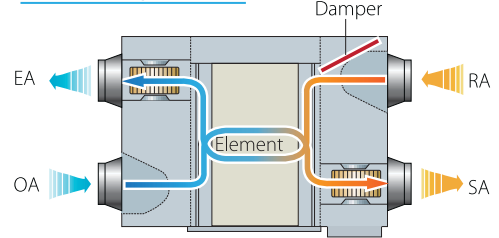

Bypass mode

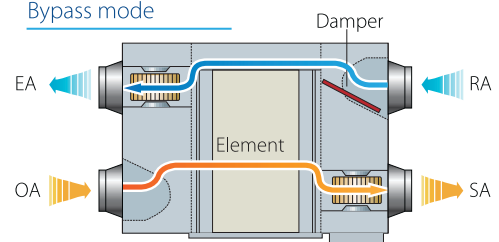

Auto mode

The controller chooses heat exchange mode or bypass mode according to the temperature difference between outdoors and indoors. Both fans are set to run at low speed.

Flexible Control

HRV can be controlled together with other indoor units.

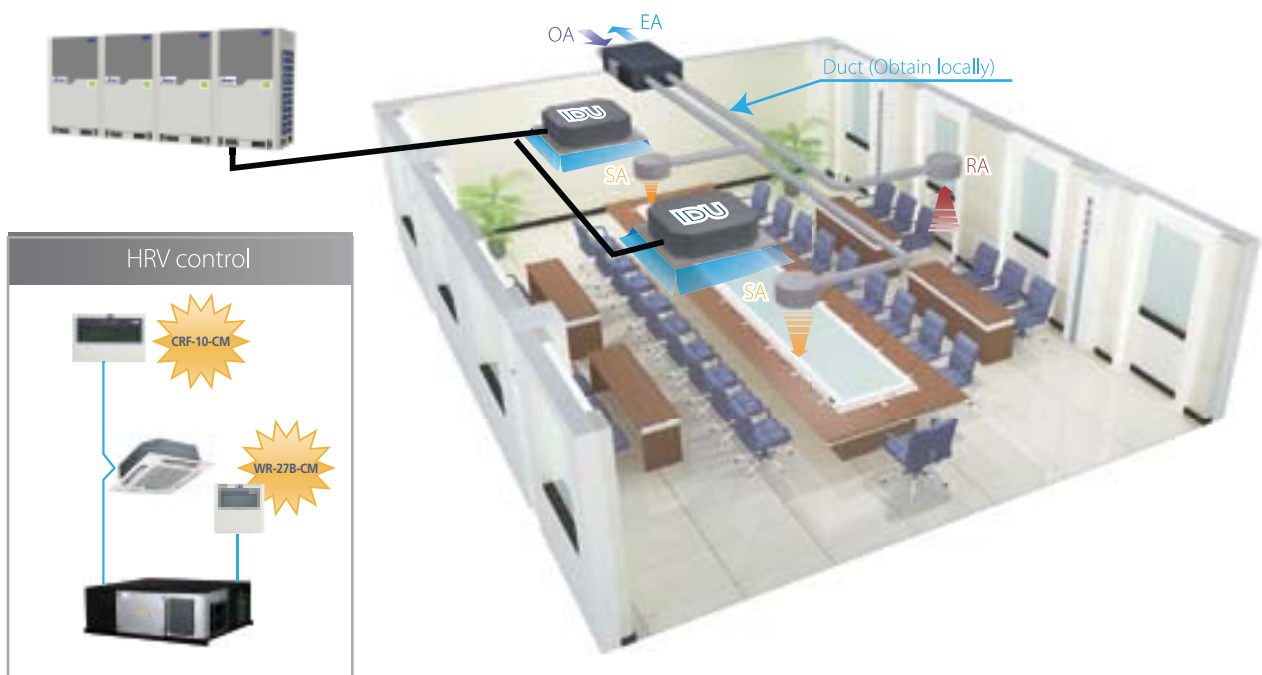

Specifications

AC fan motors

Model				HRV-200	HRV-300	HRV-400	HRV-500	
Power supply				1-phase,220-240V,50Hz		1-phase,220-240V,50Hz (1-phase,220V,60Hz)		
Cooling	Temperature exchange efficiency	High	%	55	55	55	55	
		Medium	%	55	55	55	55	
		Low	%	60	60	60	60	
	Enthalpy exchange efficiency	High	%	50	50	50	50	
		Medium	%	50	50	50	50	
		Low	%	55	55	55	55	
Heating	Temperature exchange efficiency	High	%	60	60	60	65	
		Medium	%	60	60	60	65	
		Low	%	65	65	65	70	
	Enthalpy exchange efficiency	High	%	55	55	60	60	
		Medium	%	55	55	60	60	
		Low	%	60	60	65	65	
Sound pressure level	Heat exchange mode	High	dB(A)	27	30	32	35	
		Medium	dB(A)	26	29	31	34	
		Low	dB(A)	20	23	25	28	
	Bypass mode	High	dB(A)	28	31	33	36	
		Medium	dB(A)	27	30	32	35	
		Low	dB(A)	22	25	27	30	
Net dimension (WxDxH)		mm	866x655x264	944x722x270	944x927x270	1038x1026x270		
Packing size (WxDxH)		mm	960x770x445	1020x810x452	1020x1020x452	1120x1120x452		
Net/gross weight		kg	23/40	26/44	31/52	41/64		
Casing		Galvanized steel plate						
Heat exchange system		Air to air cross flow total heat (sensible heat + latent heat) exchange						
Heat exchange element material		Specially processed nonflammable paper						
Fan	Type		Centrifugal fan					
	Airflow rate	High	m ³ /h	200	300	400	500	
		Medium	m ³ /h	200	300	400	500	
		Low	m ³ /h	150	225	300	375	
	ESP	High	Pa	75	75	80	80	
		Medium	Pa	58	60	65	68	
		Low	Pa	35	40	43	45	
Motor output		W	20	40	80	120		
Duct diameter		mm	Φ144	Φ144	Φ144	Φ194		
Operating temperature range		°C	-7~43 DB, 80% RH or less					

Model				HRV-800	HRV-1000	HRV-1500	HRV-2000	
Power supply				1-phase,220-240V,50Hz (1-phase,220V,60Hz)		3-phase,380-415V,50Hz (3-phase,220V,60Hz)		
Cooling	Temperature exchange efficiency	High	%	55	55	55	55	
		Medium	%	55	55	/	/	
		Low	%	60	60	/	/	
	Enthalpy exchange efficiency	High	%	50	50	50	50	
		Medium	%	50	50	/	/	
		Low	%	55	55	/	/	
Heating	Temperature exchange efficiency	High	%	65	65	65	65	
		Medium	%	65	65	/	/	
		Low	%	70	70	/	/	
	Enthalpy exchange efficiency	High	%	60	60	60	60	
		Medium	%	60	60	/	/	
		Low	%	65	65	/	/	
Sound pressure level	Heat exchange mode	High	dB(A)	39	40	51	53	
		Medium	dB(A)	38	39	/	/	
		Low	dB(A)	32	33	/	/	
	Bypass mode	High	dB(A)	40	41	52	54	
		Medium	dB(A)	39	40	/	/	
		Low	dB(A)	34	35	/	/	
Net dimension (WxDxH)		mm	1286x1006x388	1286x1256x388	1600x1270x540	1650x1470x540		
Packing size (WxDxH)		mm	1380x1100x573	1400x1370x573	1710x1410x720	1760x1610x720		
Net/gross weight		kg	62/88	79/110	163/224	182/247		
Casing		Galvanized steel plate						
Heat exchange system		Air to air cross flow total heat (sensible heat + latent heat) exchange						
Heat exchange element material		Specially processed nonflammable paper						
Fan	Type		Centrifugal fan					
	Airflow rate	High	m ³ /h	800	1000	1500	2000	
		Medium	m ³ /h	800	1000	/	/	
		Low	m ³ /h	600	750	/	/	
	ESP	High	Pa	100	100	160	170	
		Medium	Pa	82	85	/	/	
		Low	Pa	54	58	/	/	
Motor output		W	360	360	450	450		
Duct diameter		mm	Φ242	Φ242	346x326	346x326		
Operating temperature range		°C	-7~43 DB, 80% RH or less					

Note:

1. For the units model of HRV (200-1000), there are 3-speed adjustable air volume (Hi, Med, Low), but the fan speed of models HRV-1500 and HRV-2000 is not adjustable.

2. Sound level is measured 1.4m below the center of the unit in an anechoic chamber.

3. Efficiency is measured under the following conditions:

* Cooling: air exhaust temp 27°C DB, 19.5°C WB; fresh air temp. 35°C DB, 28°C WB.

* Heating: air exhaust temp 21°C DB, 13°C WB; fresh air temp. 5°C DB, 2°C WB.

DC fan motors

Sale Model			HRV-D200	HRV-D300	HRV-D400	HRV-D500
Power supply		V-Ph-Hz	1-phase,220-240V,50/60Hz			
Cooling	Temp. exchange efficiency	%	76.1	74.8	76.2	76.1
	Enthalpy exchange efficiency	%	77.3	76.1	78.7	78.2
Heating	Temp. exchange efficiency	%	76.1	74.8	76.2	76.1
	Enthalpy exchange efficiency	%	82.6	79.8	83.6	80.4
Input power		W	61	98	109	170
Current		A	0.72	0.99	1.07	1.56
Indoor fan motor	Model		WZDK100-38G-1	WZDK100-38G-1	WZDK100-38G-1	WZDK100-38G-1
	Insulation class		E			
	Output	W	26*2	42*2	46*2	72*2
	Pole number		8P	8P	8P	8P
	Speed	r/min	1390	1390	1390	1380
Indoor fan	material		ABS			
	Type		Centrifugal fan			
	Diameter	mm	Φ154	Φ194	Φ194	Φ203
	Height	mm	102	100	100	151
Indoor external static pressure (Hi)		Pa	75	75	80	80
Nominal air flow		m ³ /h	200	300	400	500
Sound pressure level		dB(A)	27	30	32	35
Net dimension (LxWxH)		mm	866x666x264	944x733x270	944x938x270	1038x1037x270
Packing size (LxWxH)		mm	960x770x445	1020x810x452	1020x1020x452	1120x1120x452
Net/Gross weight		kg	25/40	27/44	32/52	35/60
Power supply wire	Wire's qty		3	3	3	3
	Code wire cross section	mm ²	2.5	2.5	2.5	2.5
Controller			Wired controller			
Fresh Air Diameter		mm	Φ144	Φ144	Φ144	Φ194
Operating temperature range		°C	-7~43DB, 80%RH or less			

Sale Model			HRV-D800	HRV-D1000	HRV-D1500	HRV-D2000
Power supply		V-Ph-Hz	1-phase,220-240V,50/60Hz			
Cooling	Temp. exchange efficiency	%	76.9	75.8	77.8	77.2
	Enthalpy exchange efficiency	%	78.1	76.9	79.2	78.7
Heating	Temp. exchange efficiency	%	76.9	75.8	77.8	77.2
	Enthalpy exchange efficiency	%	80.1	78.6	80.5	80.3
Input power		W	246	360	725	1340
Current		A	2.28	3.1	5.29	9.11
Indoor fan motor	Model		WZDK170-38G-2	WZDK170-38G-2	WZDK750-38G-W-1	WZDK750-38G-W-1
	Insulation class		E			
	Output	W	104*2	153*2	308*2	570*2
	Pole number		8P	8P	8P	8P
	Speed	r/min	1150	1230	1220	1390
Indoor fan	material		ABS		metal	
	Type		Centrifugal fan			
	Diameter	mm	Φ245	Φ245	Φ234	Φ234
	Height	mm	203	203	261	261
Indoor external static pressure (Hi)		Pa	100	100	160	170
Nominal air flow		m ³ /h	800	1000	1500	2000
Sound pressure level		dB(A)	39	40	51	53
Net dimension (LxWxH)		mm	1286x1017x388	1286x1267x388	1600x1270x540	1650x1470x540
Packing size (LxWxH)		mm	1380x1100x573	1400x1370x573	1710x1410x720	1760x1610x720
Net/Gross weight		kg	58/88	69/100	151/224	165/247
Power supply wire	Wire's qty		3	3	3	3
	Code wire cross section	mm ²	2.5	2.5	2.5	2.5
Controller			Wired controller			
Fresh Air Diameter		mm	Φ242	Φ242	346x326	346x326
Operating temperature range		°C	-7~43DB, 80%RH or less			

Note:

1. For the units model of HRV-D200~HRV-D2000, there are 3-speed adjustable air-volume (Hi, Med, Low).

2. All the parameters is measured at the high speed air-volume.

3. Sound level is measured 1.4m below the center of the unit in an anechoic chamber.

4. Efficiency is measured under the following conditions:

* Cooling: air exhaust temp 27°C DB, 19.5°C WB; fresh air temp. 35°C DB, 28°C WB.

* Heating: air exhaust temp 21°C DB, 13°C WB; fresh air temp. 5°C DB, 2°C WB.



Branch Pipe



Branch Pipe



Branch joints of two-pipe refrigerant system

Model	Appearance	Model name	Packing Size (mm)	Gross Weight (kg)	Description
Branch joint for R410A outdoor unit		BJC-02-CM(i)	255×150×185	1.5	For two outdoor units connection
		BJC-03-CM(i)	345×160×285	3.4	For three outdoor units connection
		BJC-04-CM(i)	475×165×300	4.8	For four outdoor units connection
Branch joint for R410A indoor unit		BJF-224-CM(i)	90×105×100	0.4	$A^* < 16.6\text{kW}$
		BJF-330-CM(i)	290×105×100	0.6	$16.6 \leq A^* < 33\text{kW}$
		BJF-710-CM(i)	310×130×125	0.9	$33\text{kW} \leq A^* < 66\text{kW}$
		BJF-1344-CM(i)	350×180×170	1.5	$66\text{kW} \leq A^* < 92\text{kW}$
		BJF-E1344-CM(i)	365×195×215	1.9	$92\text{kW} \leq A^*$

A*:The total capacity of indoor units which is connected to this branch joint

Dimensions

Outdoor branch joints

Model	Gas side joints	Liquid side joints
BJC-02-CM(i)		
BJC-03-CM(i)		
BJC-04-CM(i)		

Indoor branch joints (2-pipe)

Model	Gas side joints	Liquid side joints
BJF-224-CM(i)		
BJF-330-CM(i)		
BJF-710CM(i)		
BJF-1344-CM(i)		
BJF-1344-CM(i)		

Dimensions

Indoor branch joins - (3-pipe)

Name	Low-pressure gas side joints	High-pressure gas side joints	Liquid side joints	Converter pipe	Heat insulation material		
BJFT-224 -CM(i)				 (Low-pressure side used)	 (High-pressure side used)	 (Liquid side used)	 (3 sets)
BJFT-330 -CM(i)				/	/	 (3 sets)	
BJFT-710 -CM(i)						 (Liquid side used)	 (3 sets)
BJFT-134 -CM(i)				/	/	 (3 sets)	
BJFT-1344 -CM(i)						 (Liquid side used)	 (3 sets)



United Technologies
turn to the experts 

AHI CARRIER SOUTH EASTERN EUROPE AIR-CONDITIONING S.A.

Headquarters

18, Kifissou Ave.
104 42 - Athens
GREECE
Tel.: +30 210 6796300
Fax: +30 210 6796390
www.ahi-carrier.gr

Thessaloniki Branch

5, Ag. Georgiyo str., Cosmos Offices
570 01 - Patriarhiko Pileas Thessaloniki
GREECE
Tel.: +30 231 3080430
Fax: +30 231 3080435

AHI Carrier HVAC BULGARIA EOOD

Trade Center Europe Building 6, floor 3, office 6
7 Iskarsko Shose Blvd., Sofia 1528
BULGARIA
Tel.: +35 929483960
Fax: +35 929483990
Email: bginfo@ahi-carrier.com
www.ahi-carrier.bg

AHI Carrier ROMANIA SRL

270d, Turnu Magurele str. Sector 4
Cavar center - Bucharest
ROMANIA
Tel.: +40 214 050751
Fax: +40 214 050753

AHI Carrier GmbH

Andromeda Tower, Donau-City Str. 6/9
1220 Wien, Österreich
AUSTRIA
Tel.: +43 (0)1 269 96 97-0
www.ahi-carrier.at

AHI Carrier CZ s.r.o.

Styblova 253/13,
14900 Praha 5, Chodov
CZECH
Tel.: +420 602 108 962
www.ahi-carrier.cz